

## TDA8432

# Computer-Controlled Deflection Processor for Video Displays

### Objective Specification

### Linear Products

### DESCRIPTION

The TDA8432 is an I<sup>2</sup>C bus-controlled deflection processor (analog picture geometry processor) which contains the control and drive functions of the deflection circuits in a computer-controlled TV (CCTV) or monitor. This IC replaces all picture geometry settings which are performed manually during manufacturing. The alignment of 10 picture geometry parameters for the vertical and horizontal deflection is accomplished by means of a microcontroller via the I<sup>2</sup>C bus. Furthermore, it eliminates the external components needed for adjusting the horizontal frequency and phase position, vertical linearity, picture height, east-west parabola, and picture width. The east-west shaping circuit is also eliminated. Provisions have been incorporated to make several sync processor (TDA2579 and TDA2595) functions I<sup>2</sup>C bus-controllable.

### FEATURES

- I<sup>2</sup>C bus interface for all functions
- Input for vertical sync from sync processor
- Vertical sawtooth generator with frequency-independent amplitude
- Vertical output stage with feedback input for driving a vertical deflection amplifier
- East-west raster correction drive output
- EHT modulation input, providing optimum picture geometry compensation for static and dynamic EHT load variations
- I<sup>2</sup>C bus-controlled alignment of 10 deflection parameters
- Provisions for controlling a sync processing IC which does not have an I<sup>2</sup>C bus interface, including:
  - Two digital-to-analog converters for alignment of the free-running horizontal frequency and horizontal phase position
  - An I/O pin enabling computer alignment of the free-running horizontal frequency
  - A special purpose 4-level output for time constant switching of the horizontal phase-locked loop
  - A special purpose 3-level input for detection of the mute function and the 50Hz/60Hz state of the sync processor
- A switchable output (e.g., for controlling a video source selector)

### APPLICATIONS

- Video monitors
- Color TV receivers

### PIN CONFIGURATION

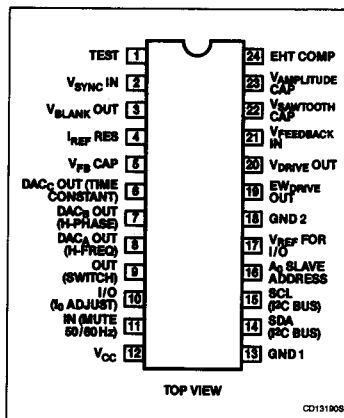

# Computer-Controlled Deflection Processor for Video Displays TDA8432

## BLOCK DIAGRAM

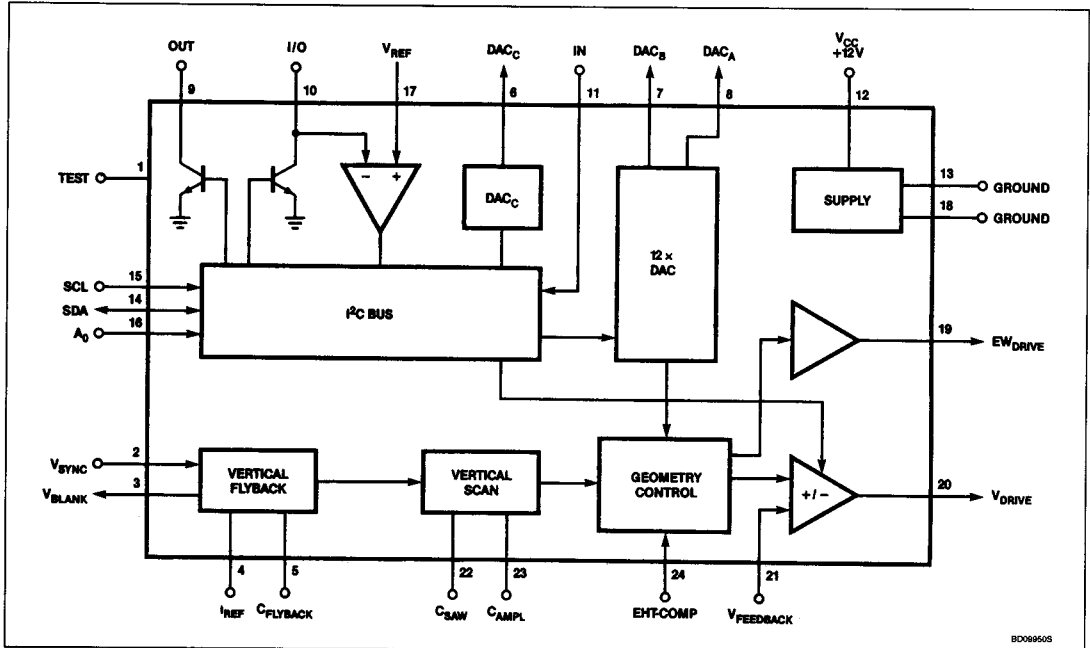

BC08950S

# Computer-Controlled Deflection Processor for Video Displays TDA8432

## ABSOLUTE MAXIMUM RATINGS

SYMBOL	PARAMETER	RATING	UNIT
V <sub>CC</sub>	Supply voltage (Pin 17)	14	V
	Switching voltage (Pin 5)	8	V
	Output currents of each pin to ground (Pins 11 and 12)	-10	mA
	Maximum short-circuit time outputs	10	sec
T <sub>STG</sub>	Storage temperature	-55 to +150	°C
T <sub>A</sub>	Operating temperature	-25 to 80	°C
T <sub>J</sub>	Junction temperature	+150	°C
θ <sub>JA</sub>	Thermal resistance	75	°C/W

**RECOMMENDED OPERATING CONDITIONS** In application circuit Figure 1 at T<sub>A</sub> = 25°C and V<sub>CC</sub> = 12V, unless otherwise specified.

SYMBOL	PARAMETER	LIMITS			UNIT
		Min	Typ	Max	
V <sub>CC</sub>	Supply voltage (Pins 17-20, 10)	10		13.2	V
I <sub>CC</sub>	Supply current (Pin 17)		42	55	mA
	Switching voltage VHF (Pin 5)	0		1.5	V
	Switching voltage hyperband	2		3.5	V
	Switching voltage UHF (Pin 5)	4		5	V
	Switching current UHF (Pin 15)			0.2	mA

## DC ELECTRICAL CHARACTERISTICS

SYMBOL	PARAMETER	LIMITS			UNIT
		Min	Typ	Max	
<b>VHF mixer including IF, measurement in circuit of Figure 1</b>					
f <sub>R</sub>	Frequency range: printed circuit board	50		300	MHz
	Noise Figure 1 (Pin 23) 50MHz		7.5	9	dB
	225MHz		9	10	dB
	300MHz		10	12	dB
	Optimum source admittance (Pin 23) 50MHz		0.5		mmho
	225MHz		1.1		mmho
	300MHz		1.2		mmho
	Input conductance (Pin 23) 50MHz		0.23		mmho
	225MHz		0.5		mmho
	300MHz		0.67		mmho
C <sub>IN</sub>	Input capacitance (Pin 23) 50MHz-300MHz		2		pF
V <sub>IN</sub>	Input voltage for 1% × mod in channel (Pin 23)	97	100		dBμV
V <sub>IN</sub>	Input voltage for 10kHz pulling (in channel) (Pin 23)	100	108		dBμV
A <sub>V</sub>	Voltage gain = 20log (V <sub>11-12</sub> /V <sub>23</sub> ) (Pins 11-12, 23)	22	24.5	27	dB
<b>VHF mixer</b>					
	Conversion transadmittance mixer = SC = I15/V23 = -I16/V23 (Pins 15, 16-23)		3.8		mmho
	Output admittance mixer (Pins 15-16)		0.1		mmho
	Output capacitance mixer (Pins 15-16)		2		pF

# Computer-Controlled Deflection Processor for Video Displays TDA8432

## DC ELECTRICAL CHARACTERISTICS (Continued)

SYMBOL	PARAMETER	LIMITS			UNIT
		Min	Typ	Max	
<b>VHF oscillator</b>					
$f_R$	Frequency range	70		330	MHz
	Shift $V_B = 10\%$ ; 70 to 330MHz			200	kHz
	Drift $T = 15^\circ$ ; 70 to 330MHz			250	kHz
	Drift from 5 seconds to 15 minutes after switching on			200	kHz
<b>Hyperband mixer including IF (measured in circuit of Figure 1<sup>2</sup>) (measurements with hybrid)</b>					
$f_R$	Frequency range	300		470	MHz
	Noise figure (Pins 21, 22) 300MHz		8	10	dB
	470MHz		8	10	dB
	Input reflection coefficient (Pins 21, 22) 300MHz $ S_{11} ^{\text{phase}}$		-4.4		dB
	470MHz $ S_{11} ^{\text{phase}}$		+162		deg
			-4.7		dB
			+151		deg
	Input available power $P_{AV}$ for 1% X-mod in-channel (Pins 21, 22) 300MHz		-19		dBm
	470MHz		-19		dBm
	10kHz pulling (in-channel) (Pins 21, 22) 470MHz		-11		dBm
	$N + 5 - 1\text{MHz}$ pulling <sup>3</sup> (Pins 21, 22) 470MHz		-29		dBm
	Gain = <sup>4</sup> 300MHz	34	37	40	dB
	470MHz	34	37	40	dB
<b>Hyperband oscillator</b>					
	Frequency range (MHz)	330		520	MHz
	Shift $\Delta V_B = 5\%$			400	kHz
	Drift $\Delta T = 15^\circ$			500	kHz
	Drift from 5 seconds to 15 minutes after switching on			600	kHz
	Input reflection coefficient (Pins 4-5) $ S_{11} $ at $f = 330\text{MHz}$		TBD		dB
	phase		TBD		deg
<b>UHF mixer including IF (Pins 18 and 19) (measured in circuit of Figure 1<sup>2</sup>) (measurements with hybrid)</b>					
	Frequency range	470		860	MHz
	Noise figure 470MHz		8	10	dB
	860MHz		9	11	dB
	Input reflection coefficient 470MHz $ S_{11} ^{\text{phase}}$		-4		deg
	860MHz		+157		deg
	phase		-4.2		deg
	phase		+138		deg
	Input available power $P_{AV}$ for 1% X-mod in-channel 470MHz		-19		dBm
	860MHz		-19		dBm
	10kHz pulling (in-channel) 860MHz		-10		dBm
	$N + 5 - 1\text{MHz}$ pulling <sup>3</sup> 820MHz	-42	-35		dBm
	Gain = <sup>4</sup> 470MHz	34	37	40	dB
	860MHz	34	37	40	dB

# Computer-Controlled Deflection Processor for Video Displays TDA8432

## DC ELECTRICAL CHARACTERISTICS (Continued)

SYMBOL	PARAMETER	LIMITS			UNIT
		Min	Typ	Max	
<b>UHF oscillator</b>					
$f_R$	Frequency range (MHz)	500		900	MHz
	Shift $\Delta V_B = 5\%$			400	kHz
	Drift $\Delta T = 25^\circ\text{C}$ to $40^\circ\text{C}$			500	kHz
	Drift from 5 seconds to 15 minutes after switching on			300	kHz
<b>IF amplifier</b>					
			<b>Mod</b>	<b>Phase</b>	
	S11 S21 S12 S22 measured at 36MHz, differentially		-0.5	-1	dB/deg
			12	160	dB/deg
			-41	-5.2	dB/deg
			-7.9	13.7	dB/deg
<b>LO output (Pin 2)</b>					
	Output voltage into $75\Omega$ $f \leq 330\text{MHz}$	14	37	100	mV
	Output reflection coefficient (VHF position) S22 (Hyperband and UHF) at 500MHz		TBD	TBD	dB/deg dB/deg
	Spurious signal on LO output wrt LO output signal, measured in $75\Omega$ with RF signal level at Pin 24 $1V \leq 225\text{MHz}$ $0.3V$ $225\text{MHz} - 300\text{MHz}$			-10	dB
	Harmonics of LO signal wrt LO signal, measured in $75\Omega$			-10	dB

### NOTES:

1. The Pins 2, 5, 11, 12, 13, 14 withstand the ESD test.
2. Measured with an input circuit for optimum noise figure.
3. The values have been corrected for hybrid and cable losses. The symmetrical output impedance of the hybrid is  $100\Omega$ .
4. The input level of an  $N + 5 - 1\text{MHz}$  signal which is just visible (Amtsblatt 69).
5. The gain is defined as the transducer gain measured in Figure 1 + the voltage transformation ratio of L6-L7. The ratio is 6:1 (16dB).
6. All S parameters are referred to a  $50\Omega$  system.

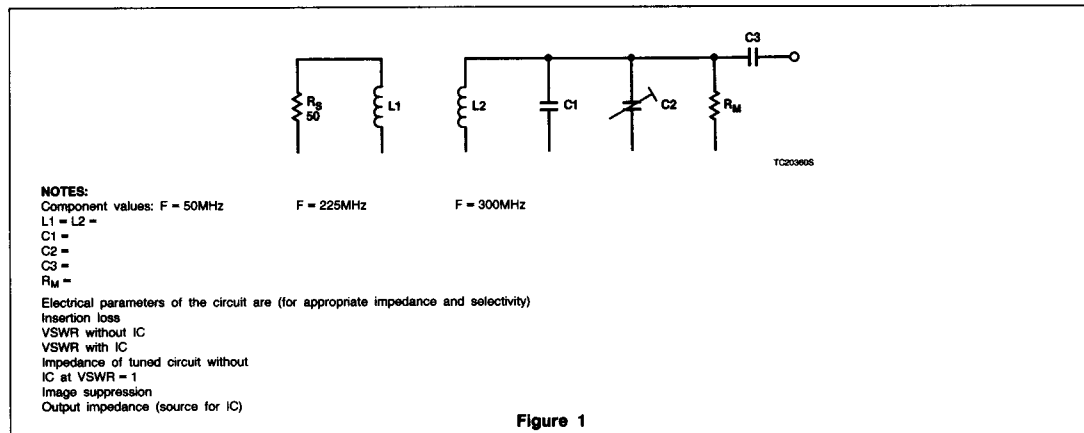

Figure 1