



TV AND VTR STEREO/DUAL SOUND PROCESSOR WITH I²C BUS CONTROL

GENERAL DATA

The TDA8405 integrated circuit is a processor for stereo/dual-language signals for stereo-sound television receivers and VTR. The modulated signals at the TDA8405 inputs need to be "(L+R)/2" or "language A" on one channel and "R" or "language B" on the second channel (where L = left and R = right). The second channel is also modulated with the pilot carrier. The IC is controlled via the two-line, bidirectional I²C bus.

Features

- Amplification of the two a.f. input signals by integrated operational amplifiers.
- Low distortion stereo dematrix
- All operational amplifiers are offset compensated
- I²C bus transceiver for system control (port control, mute, mode select, identification, etc.)
- Input port for fast muting
- Two general purpose output ports (three-state, bus-controlled)

QUICK REFERENCE DATA

Supply voltage	$V_P = V_{18-9-15}$	typ. 12 V
Supply current	$I_P = I_{18}$	typ. 25 mA
A.F. input signal	$V_{i(rms)} = V_{6-9}, V_{8-9}$	typ. 1 V
Weighted signal-to-noise ratio of the a.f. output-signals (CCIR 468/2)	$(S+N)/N$	\geq 70 dB
Crosstalk attenuation: stereo mode at $f = 1$ kHz	α_S	$>$ 40 dB
dual sound mode at $f = 40$ to $12\,500$ Hz	α_{DS}	$>$ 70 dB
Pilot signal input sensitivity	$V_i = V_{5-9(rms)}$	typ. 5 mV
Pilot signal amplifier gain control range	ΔG_V	$>$ 40 dB

PACKAGE OUTLINE

28-lead DIL; plastic (SOT-117).

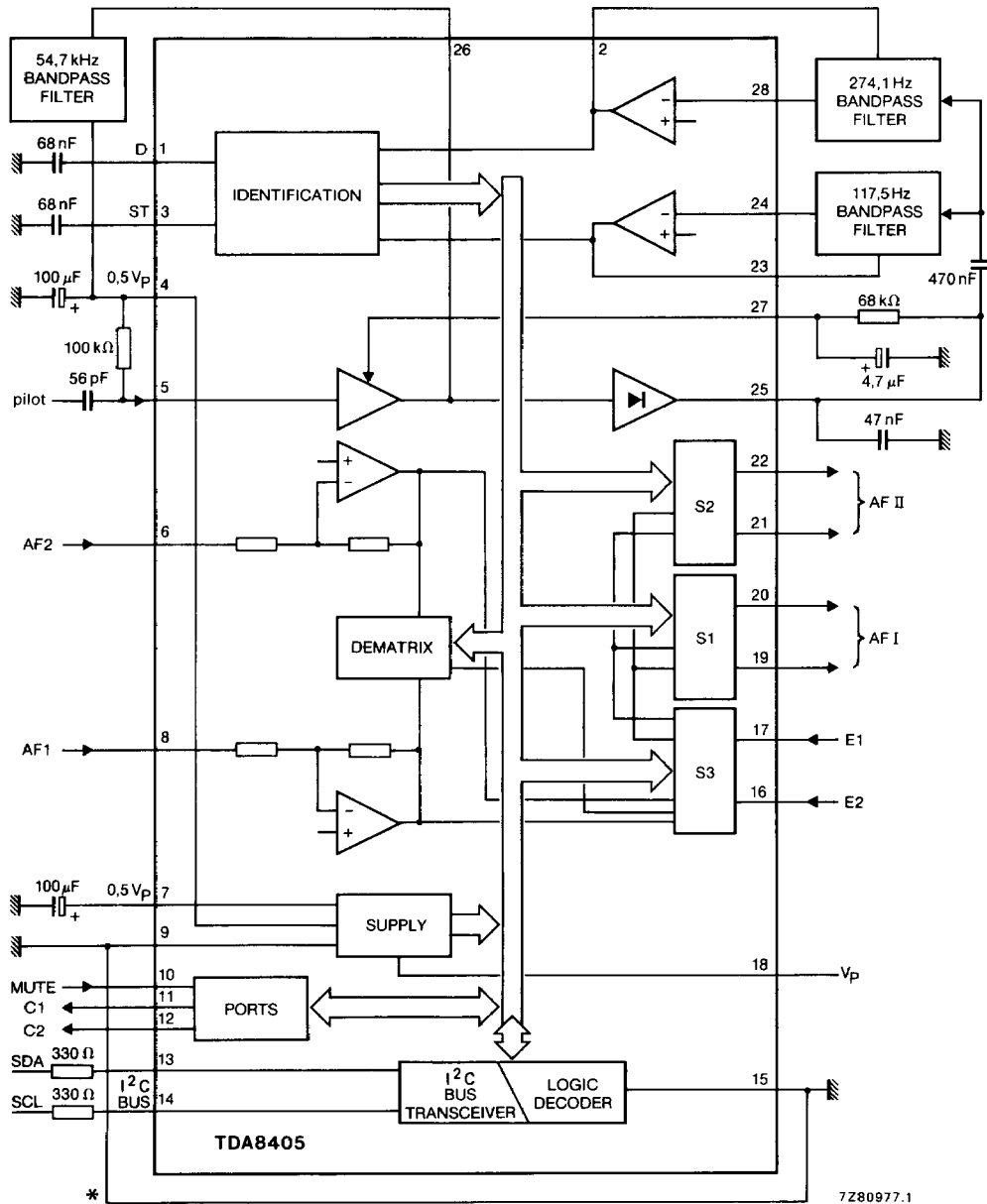

* Direct connection between pins 9 and 15 is needed.

Fig. 1 Block diagram.

RATINGS

Limiting values in accordance with the Absolute Maximum System (IEC 134)

Supply voltage (pin 18)*	$V_P = V_{18-9, 15}$	max.	13,2 V
Output current (pins 19, 20, 21, 22)	I_n	max.	5 mA
Output current (pins 2, 23)	I_n	max.	1 mA
Output current (pins 11, 12)	I_n	max.	3 mA
Voltage range at any pin	V_n		0 to V_P V
Total power dissipation	P_{tot}	max.	1 W
Storage temperature range	T_{stg}		-40 to + 150 °C
Operating ambient temperature range	T_{amb}		0 to + 70 °C

DEVELOPMENT DATA

* Supply voltage may be applied only when pins 9 and 15 are connected to ground.

CHARACTERISTICS

$T_{amb} = 25\text{ }^{\circ}\text{C}$; $V_P = 12\text{ V}$; $V_{i(af)rms} = 1\text{ V}$; $f = 1\text{ kHz}$; dematrix aligned; $V_{i\text{ pilot}(rms)} = 16\text{ mV}$; test circuit Fig. 2; unless otherwise specified.

parameter	symbol	min.	typ.	max.	unit
Supply voltage	$V_P = V_{18-9, 15}$	10,8	12	13,2	V
Supply current at $V_P = 12\text{ V}$	$I_P = I_{18}$	—	25	—	mA
Reference voltage	$V_{ref} = V_{4-9, 15}$	—	$V_P/2$	—	V
DC levels (pins 5, 6, 7, 8, 16, 17, 19, 20, 21, 22, 24, 28)	$V_{n-9, 15}$	—	$V_P/2$	—	V
BUS TRANSCEIVER (pins 13, 14)					
(note 1)					
Clock SCL					
Voltage level LOW	V_{14-15}	-0,3	—	1,5	V
Voltage level HIGH	V_{14-15}	3,0	—	—	V
Timing LOW period	t_{PL}	4,7	—	—	μs
Timing HIGH period	t_{PH}	4,0	—	—	μs
Rise time	t_r	—	—	1	μs
Fall time	t_f	—	—	0,3	μs
Input current HIGH	I_{IH}	—	—	10	μA
Input current LOW	$-I_{IL}$	—	—	10	μA
Data					
Voltage level LOW	V_{13-15}	-0,3	—	1,5	V
Voltage level HIGH	V_{13-15}	3,0	—	—	V
Rise time	t_r	—	—	1,0	μs
Fall time	t_f	—	—	0,3	μs
Set-up time data	t_{SU}	0,25	—	—	μs
Input current HIGH	I_{13}	—	—	10	μA
Input current LOW	$-I_{13}$	—	—	10	μA
Output current LOW	$+I_{13}$	3,0	—	—	mA
MUTE PORT (pin 10) note 2					
Input voltage LOW	V_{10-15}	—	—	1,5	V
Input voltage HIGH	V_{10-15}	8	—	—	V

DEVELOPMENT DATA

parameter	symbol	min.	typ.	max.	unit
CONTROL PORTS (pins 11, 12)					
3-state HIGH, LOW, high ohmic					
Output resistance in open state	R _{11, 12-15}	50	—	—	kΩ
Output voltage LOW	V _{11, 12-15}	—	—	0,8	V
Output voltage HIGH	V _{11, 12-15}	V _{p-1}	—	—	V
Output current LOW	I _{11, 12}	500	—	—	μA
Output current HIGH	-I _{11, 12}	80	—	—	μA
IDENTIFICATION (See Fig. 3)					
Input amplifier and demodulator					
Input voltage	V _{5-9(p-p)}	—	—	2,0	V
Min. input voltage	V _{5-9(rms)}	5,0	—	—	mV
Input resistance	R ₅₋₉	500	—	—	kΩ
Gain	G ₂₅₋₉	—	42	—	dB
Gain control range	ΔG	40	—	—	dB
Output voltage (gain-controlled)	V _{25-9(p-p)}	—	1,5	—	V
Operational amplifiers					
Input current	I _{24, 28}	—	70	—	nA
Gain at f = 200 Hz	G _{23-24, G2-28}	78	—	—	dB
Output current	I _{2, 23}	1,5	—	—	mA
Output resistance	R _{2, 23-9}	—	2	—	kΩ
Output load capacitance	C _{2, 23-9}	—	—	30	pF
Schmitt trigger					
A.C. input signal	V _{2, 23-9(rms)}	—	1	—	V
Internal discharge resistors	R _{1, 3-9}	—	3	—	kΩ
A.F. STAGES					
Input resistance (pins 6, 8, 16 and 17)	R _{n-9}	10	—	—	kΩ
Gain (V _{19, 20, 21, 22-9/V_{6, 8-9}})	G ₁	—	6	—	dB
Gain (V _{19, 20, 21, 22-9/V_{16, 17-9}})	G ₂	—	0	—	dB
Input voltage	V _{6, 8-9(rms)}	—	1	—	V
Crosstalk attenuation (notes 3, 4 and 9)					
dual sound	α _{DS}	70	—	—	dB
stereo f = 250 Hz to 6,3 kHz	α _S	40	—	—	dB
stereo f = 40 Hz to 250 Hz; 6,3 kHz to 12,5 kHz	α _S	30	—	—	dB

CHARACTERISTICS (continued)

parameter	symbol	min.	typ.	max.	unit
A.F. STAGES (continued)					
Output resistance	$R_{19,20,21,22}$	—	200	300	Ω
Output load capacitance (pins 19, 20, 21 and 22)	C_{n-9}	—	—	1,5	nF
D.C. offsets (note 8) at pins 19,20,21 and 22	ΔV	—	—	30	mV
Total harmonic distortion (notes 4 and 5)	THD	—	0,1	0,5	%
Output signal (r.m.s. value) (pins 19, 20, 21 and 22)	$V_{n-9(rms)}$	—	—	2,0	V
Ripple rejection (note 6)	RR	30	35	—	dB
Noise rejection (note 7) (noise from I ² C bus)	NR	80	—	—	dB
Signal-to-noise ratio (note 7)	(S+N)/N	70	—	—	dB
Ident signal suppression		70	—	—	dB
Signal suppression during mute (notes 4 and 7)		70	—	—	dB

Notes to the characteristics

1. Full specification of the I²C bus will be supplied on request.
2. Programmable mute state. If the SC3 bit in the I²C bus is LOW then the mute input is active LOW; if the mute bit is set to HIGH then the mute input is active HIGH.
3. Crosstalk attenuation definition: 20 log (unwanted output signal/input signal).
4. Frequency range: 40 Hz < f < 12,5 kHz.
5. In dual sound mode.
6. Test circuit as in Fig. 4: ripple rejection = output modulation due to hum on the supply line.
7. Related to 2 V (r.m.s.) output signal at pin 19, 20, 21 or 22; noise weighted according to CCIR 468/2.
8. Caused by any change of the switch position.
9. α_5 measured without de-emphasis network.

DEVELOPMENT DATA

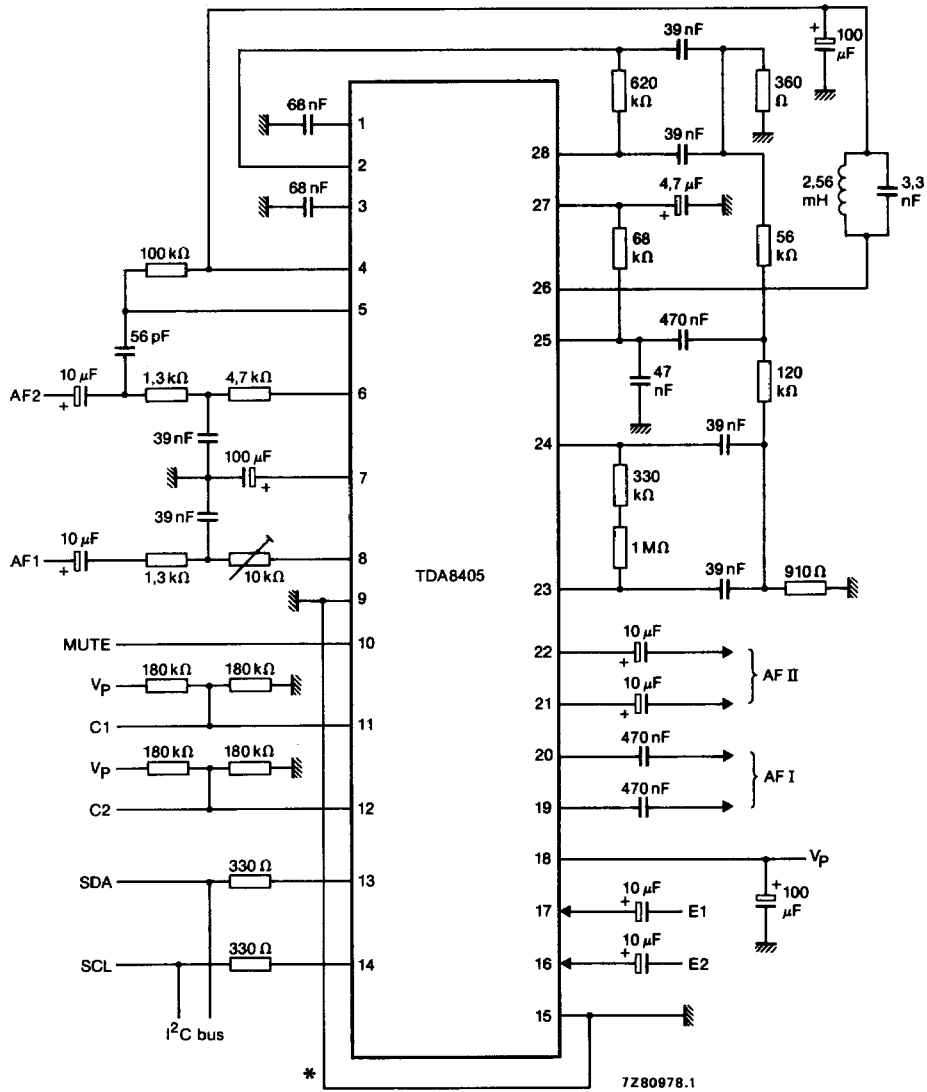

* Direct connection between pins 9 and 15 is needed.

Fig. 2 Test circuit.

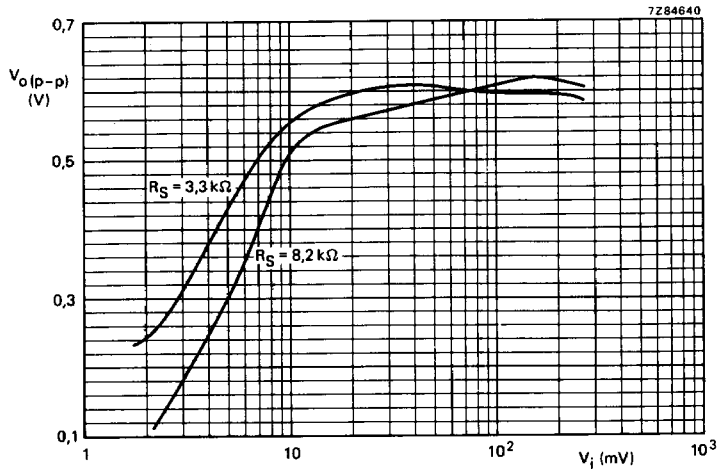

Fig. 3 Controlled output voltage as a function of the input signal ($Q = 80$); pilot frequency $f_o = 54$ kHz; R_S = source resistance.

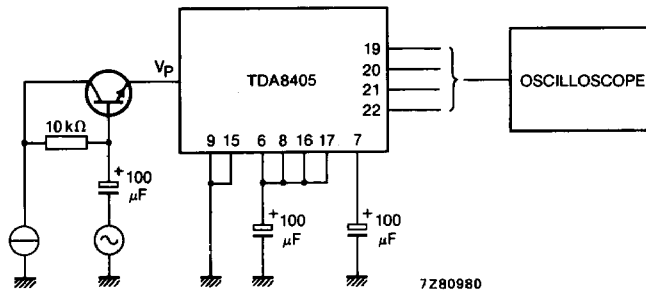

Fig. 4 Test circuit for ripple rejection: supply (d.c.) + pulse (r.m.s.) voltage at 100 Hz = 12 V + 50 mV.

DEVELOPMENT DATA

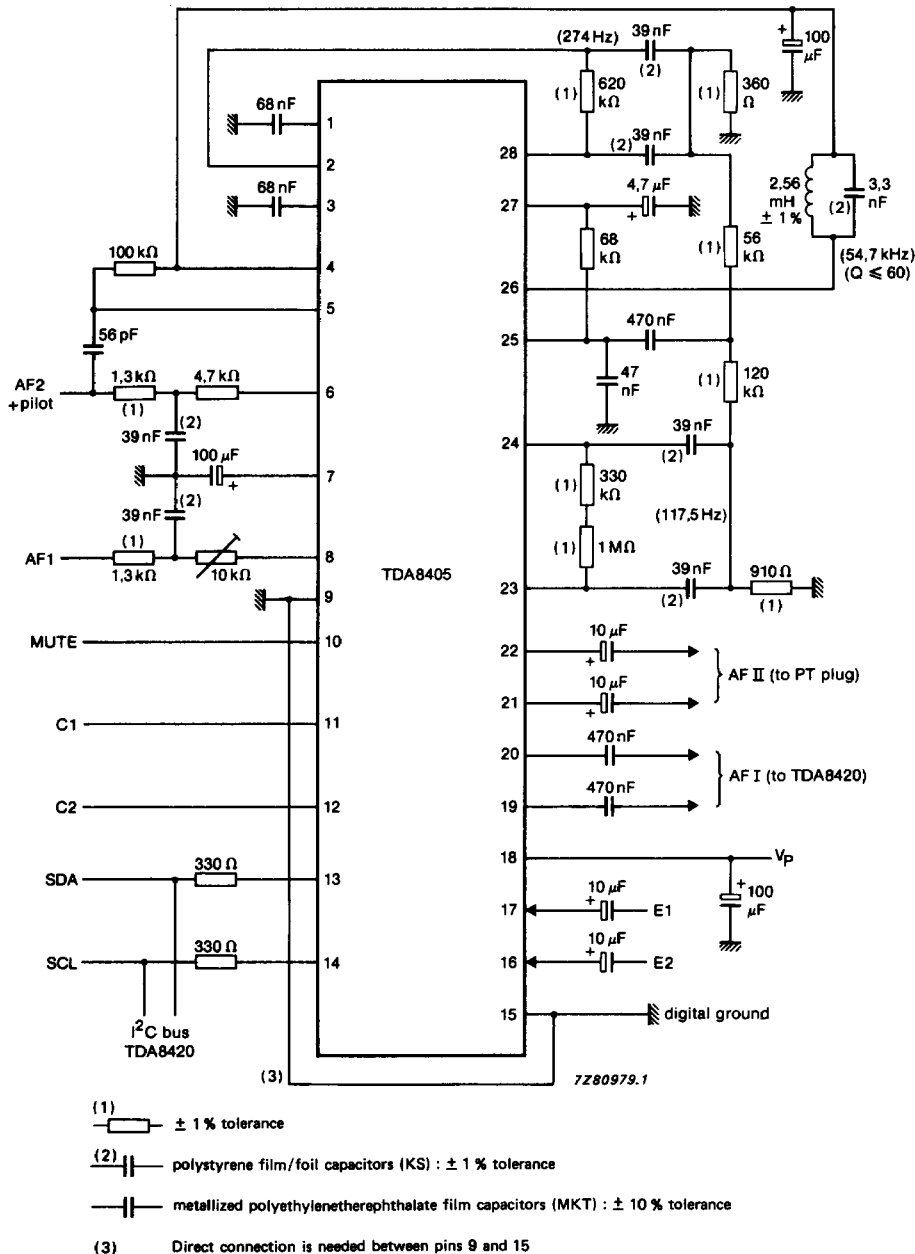

Fig. 5 Application diagram.