

# DATA SHEET



## **TDA4821P** Autosize IC for colour monitors

Product specification  
File under Integrated Circuits, IC02

2000 Feb 09

## Autosize IC for colour monitors

## TDA4821P

### FEATURES

- Measuring of six horizontal and four vertical timing parameters as follows:
  - Horizontal: sync width, sync period, video start, video end and horizontal flyback pulse start and end
  - Vertical: sync width, sync period, first line of video active and last line of video active.
- Detection of H-sync and V-sync polarity
- I<sup>2</sup>C-bus interface (maximum clock frequency 400 kHz) for read-out of data and write data of the internal clock multiplier using double byte (16-bit format)
- Flexible digital clock input with built-in and (via I<sup>2</sup>C-bus) adjustable clock multiplier; internal clock is 48 MHz (typical value)
- Horizontal measurements are expressed in number of clock pulses; precision is approximately 20 ns at 48 MHz and can be improved if external averaging methods are used
- Vertical measurements are expressed in number of lines
- Internal buffer keep I<sup>2</sup>C-bus registers stable between the V-sync pulses, allowing for asynchronous read-out.



The advantages are:

- A more user friendly adjustment for any undefined video mode by simply pressing a button
- Factory alignment for a reduced number of modes
- Saving of EEPROM storage space for factory and user modes.

The activation of the autosizing function can be done on user command or automatically on any mode change. When autosizing is activated while the screen is only partly active or consists of sub-windows, the picture size will increase, but not more than the range limits of the monitor allow.

### GENERAL DESCRIPTION

The TDA4821P performs the 'autosize' feature for colour monitors. The IC measures the timing of active H/V video with respect to the H-sync and V-sync pulses and also with respect to the horizontal flyback pulse in order to allow the microcontroller to adjust the display settings automatically, in particular parameters HSIZE, VSIZE, HPOS and VPOS.

### ORDERING INFORMATION

TYPE NUMBER	PACKAGE		
	NAME	DESCRIPTION	VERSION
TDA4821P	DIP20	plastic dual in-line package; 20 leads (300 mil)	SOT146-1

## Autosize IC for colour monitors

## TDA4821P

**QUICK REFERENCE DATA**

Voltages measured with respect to pins  $V_{SS(I/O)}$  and  $V_{SS(core)}$ .

SYMBOL	PARAMETER	CONDITIONS	MIN.	TYP.	MAX.	UNIT
$V_{DD(core)}$	core supply voltage (pin 15)		3	3.3	3.6	V
$V_{DD(I/O)}$	I/O supply voltage (pin 6)		3	3.3	3.6	V
$V_{DD(PLL)}$	PLL supply voltage (pin 3)		3	3.3	3.6	V
$V_{VIN1}$	video channel 1 input voltage (pin 1)	AC-coupled with 10 nF	0	–	$V_{DD} - 0.5$	V
$V_{VIN2}$	video channel 2 input voltage (pin 2)	AC-coupled with 10 nF	0	–	$V_{DD} - 0.5$	V
$V_{VIN3}$	video channel 3 input voltage (pin 19)	AC-coupled with 10 nF	0	–	$V_{DD} - 0.5$	V
$V_{clamp(ref)}$	default clamping level for video channel inputs (pins 1, 2 and 19)	internal default value	360	400	440	mV
$V_{slice}$	slicing voltage for video comparators		450	500	550	mV
$f_{clk(ext)}$	external input clock frequency (pin 4)		4	–	16	MHz
$f_{clk(int)}$	internal clock frequency	$f_{clk(int)} = f_{clk(ext)} \times M_{clk}$	18	48	72	MHz
$M_{clk}$	clock multiplying factor	adjustable via I <sup>2</sup> C-bus	1	–	8	–
$t_{res(h)}$	time resolution for horizontal measurements	without external averaging methods; $f_{clk(int)} = 48$ MHz	–	20	–	ns
$f_{SCL}$	I <sup>2</sup> C-bus serial clock frequency		–	–	400	kHz

Autosize IC for colour monitors

TDA4821P

BLOCK DIAGRAM

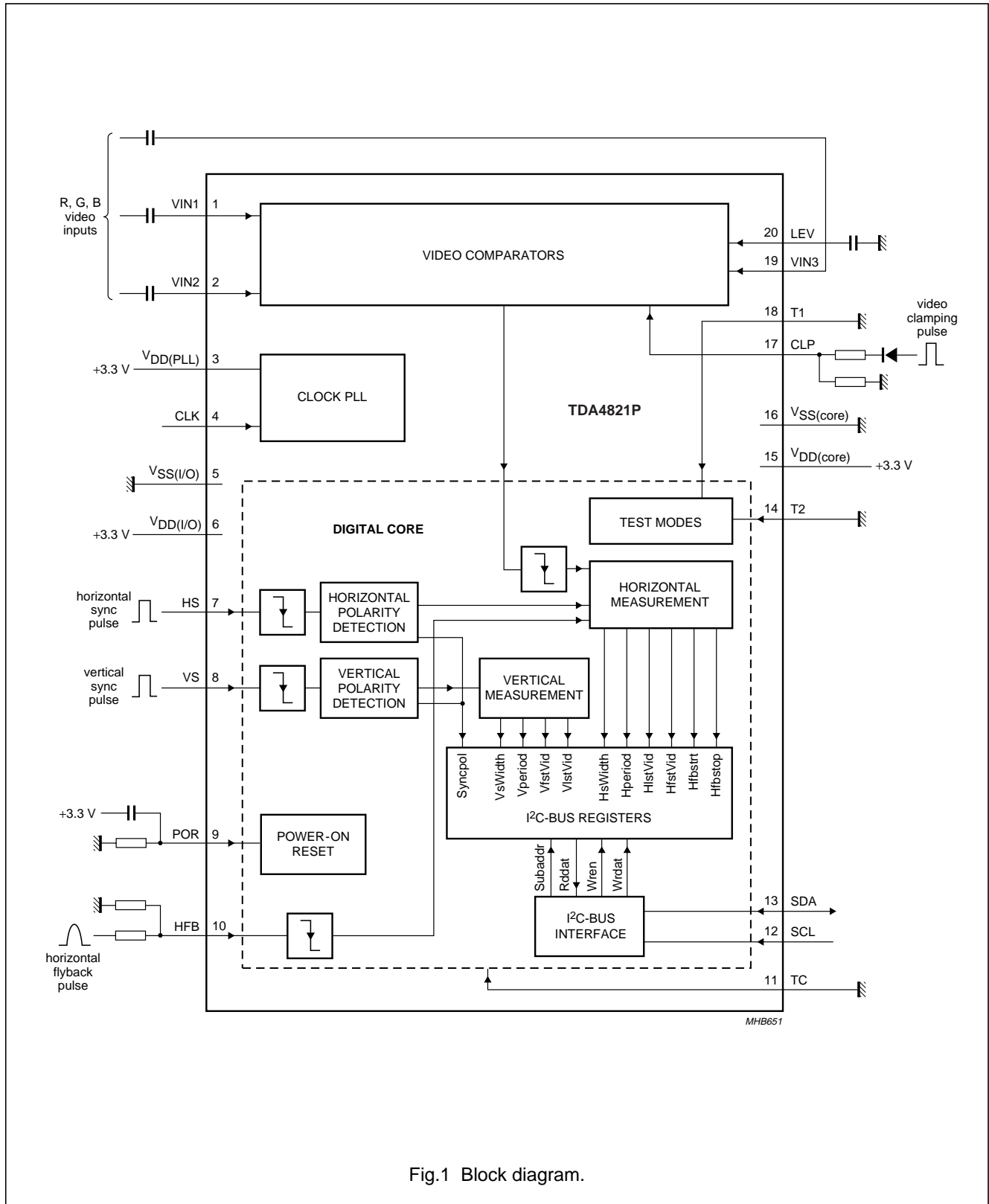

Fig.1 Block diagram.

Autosize IC for colour monitors

TDA4821P

**PINNING**

SYMBOL	PIN	DESCRIPTION
VIN1	1	video channel 1 input
VIN2	2	video channel 2 input
V <sub>DD(PLL)</sub>	3	analog supply voltage of PLL
CLK	4	clock input
V <sub>SS(I/O)</sub>	5	ground of input/output circuit
V <sub>DD(I/O)</sub>	6	supply voltage of input/output circuit
HS	7	horizontal sync pulse input
VS	8	vertical sync pulse input
POR	9	Power-on reset input
HFB	10	horizontal flyback pulse input
TC	11	test control input
SCL	12	I <sup>2</sup> C-bus serial clock input
SDA	13	I <sup>2</sup> C-bus serial data input/output
T2	14	test mode 2 input
V <sub>DD(core)</sub>	15	supply voltage of digital core and comparator
V <sub>SS(core)</sub>	16	ground of digital core
CLP	17	video clamping pulse input
T1	18	test mode 1 input
VIN3	19	video channel 3 input
LEV	20	video clamping level input

**FUNCTIONAL DESCRIPTION**

The TDA4821P consists of an RGB video comparator input stage (see Fig.1), a clock PLL for multiplying the external clock and a digital core which includes the comparators for H-sync, V-sync and H-flyback pulses, the polarity detection, the horizontal and vertical time measurement blocks, the I<sup>2</sup>C-bus registers and interface and the Power-on reset circuitry.

**RGB video input stage**

Three video input comparators are provided, suitable for AC-coupling with capacitors of approximately 10 nF on each input. The input pins VIN1, VIN2 and VIN3 are suitable for the RGB video signals. The three input signals are internally applied to an OR-circuit, so the presence of one video signal is sufficient to activate the capture registers.

A positive pulse is needed on pin CLP for black level clamping. This clamping pulse must not coincide with a possible Sync-On-Green (SOG) because SOG will not be detected by this IC.

The black level of the video signal on pins VIN1, VIN2 and VIN3 is clamped internally to 400 mV (typical value). This clamping level is determined by an internal divider which is available on pin LEV and can be adjusted by an additional external resistor divider connected to pin LEV (see Fig.5). A small HF decoupling capacitor is needed on pin LEV.

The video slicing level for the detection of active video is 500 mV (typical value). This level is approximately 100 mV above the black level and is fixed by an additional internal resistor divider from the 3.3 V supply voltage; it cannot be modified. All signals which exceed this level are recognized as active video. The difference between the video slicing level and the clamping level is adjustable via pin LEV.

Example: changing the voltage on pin LEV from 400 to 200 mV increases the threshold voltage for the detection of active video from 100 to 300 mV.

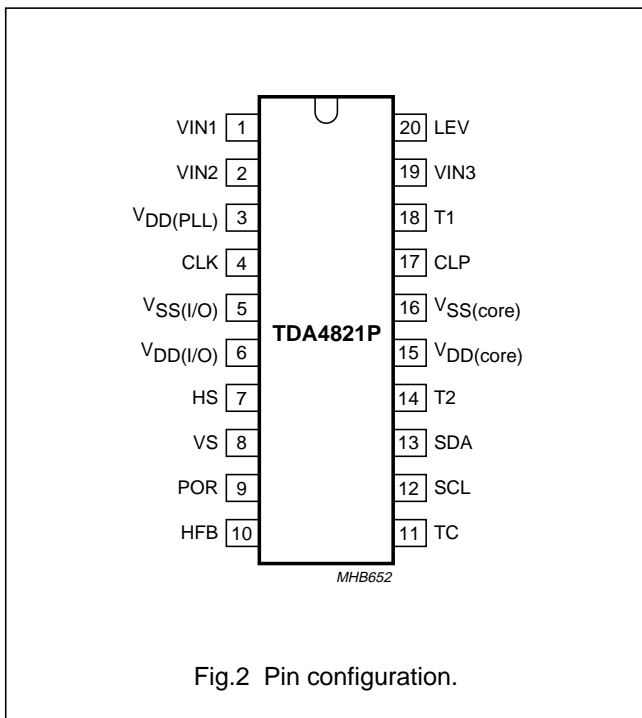

Fig.2 Pin configuration.

## Autosize IC for colour monitors

## TDA4821P

### Clock PLL

In order to measure the horizontal timing with sufficient precision, it is recommended to set the frequency of the internal reference clock to 48 MHz. This clock is generated by a multiplying PLL from the external clock signal applied to pin CLK. The ratio between the internal and external clock frequency (clock multiply factor is  $M_{clk}$ ) is programmable from 1 to 8 (via the I<sup>2</sup>C-bus). For instance, for an external clock frequency of 8 MHz, a multiply factor  $M_{clk} = 6$  is needed to achieve an internal reference clock of 48 MHz.

After power-on of the IC and with an inactive I<sup>2</sup>C-bus, the default value of factor  $M_{clk}$  is set to 2.

### Sync and flyback pulse comparators and polarity detection

The horizontal and vertical sync pulse input circuits on pins HS and VS are able to handle both 5 or 3.3 V level H/V sync pulses. The H-sync and V-sync signals are internally preprocessed by edge detectors which deliver positive pulses at the rising and falling edges of the input signals and are followed by auto-polarity correction stages. The polarity status of both sync signals will be detected and corrected and is available as the I<sup>2</sup>C-bus status bits Hpol and Vpol. A positive polarity means that the duty cycle is smaller than 50% (bit Hpol = 0 or bit Vpol = 0) and for a negative polarity the duty cycle is larger than 50%.

The horizontal flyback pulse on pin HFB is internally preprocessed by an edge detector in the same way as for H-sync and V-sync pulses. The measurement of the position of the horizontal flyback pulse provides further information for the monitor microcontroller for a correct auto-adjustment of the picture within the scanned raster area.

### Horizontal and vertical timing measurements

For each vertical period the IC performs six horizontal and four vertical measurements (see Figs 3 and 4).

The leading edge of the next vertical sync pulse is used to transfer the previous measurement results to the I<sup>2</sup>C-bus data read registers and to reset the internal counters for the next full timing measurement cycle. In this way the I<sup>2</sup>C-bus data registers will always contain stable sample-and-hold data (assuming that the sync signals are stable) and they can be read-out via the I<sup>2</sup>C-bus by an external microcontroller for automatic adaption of the display geometry.

Moreover, measuring the width of the sync pulses gives more advantages such as:

- A better mode discrimination
- In some cases the horizontal PLL of the deflection controllers operates on the leading edge of the sync pulse, in other cases in the middle of the sync pulse.

#### VERTICAL TIMING MEASUREMENTS

The parameters are measured with respect to the leading edge of the V-sync pulse (see Fig.3). At each leading edge of the V-sync pulse on pin VS a 12-bit counter is started. The four vertical timings (see Table 1) are counted as a number of H-sync pulses on pin HS and stored in buffer registers. The contents of these buffer registers are copied to the I<sup>2</sup>C-bus registers on every next V-sync pulse with the addition of LSBs (logic 0) for completing the full 2-byte data (see Table 4).

The maximum line count is 4095. With Enhanced Graphics Adapter (EGA) systems with approximately 400 lines at 31.45 kHz, the lower line count will be 9 bits long only but the resolution is still better than 0.25%. No provisions are included for recognizing interlaced sync signals with or without equal vertical periods.

Autosize IC for colour monitors

TDA4821P

**Table 1** Vertical timing measurements

TIMING	BITS	CONDITIONS
VsWidth	8	trailing edge of pulse on pin VS
VfstVid	12	first line with active video on pins VIN1, VIN2 or VIN3
VlstVid	12	last line with active video on pins VIN1, VIN2 or VIN3
Vperiod	12	next leading edge of pulse on pin VS

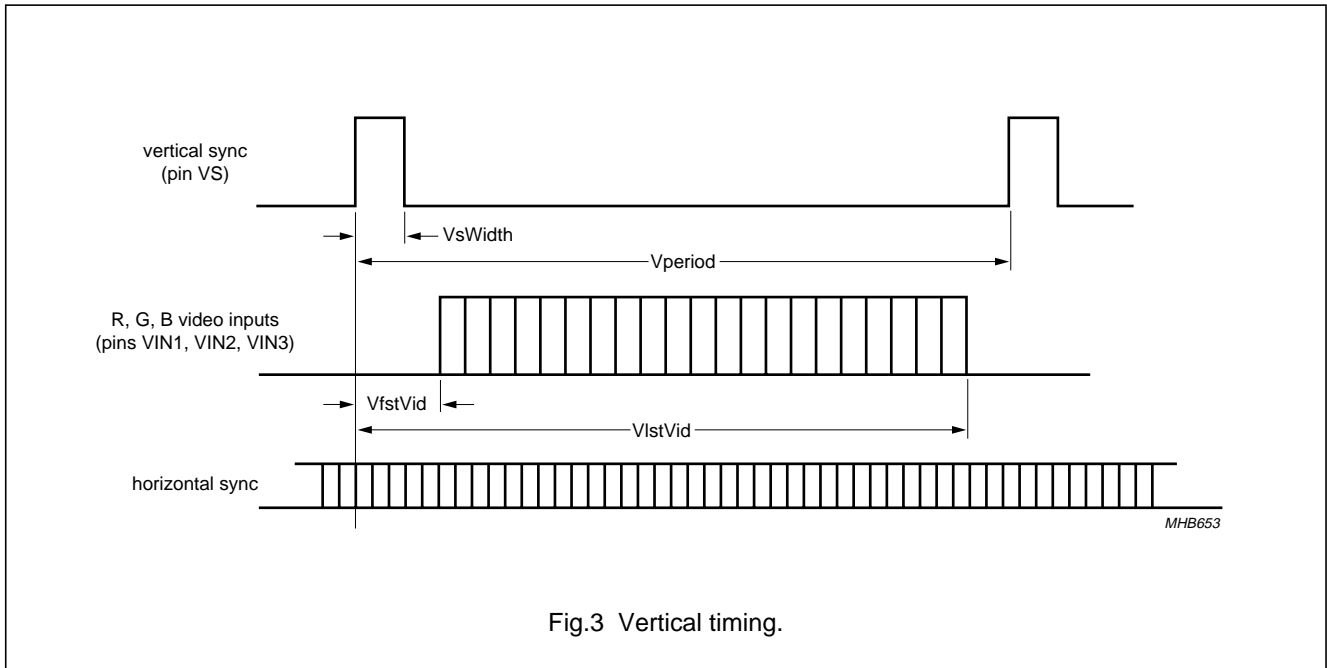

**HORIZONTAL TIMING MEASUREMENTS**

The parameters are measured with respect to the leading edge of the H-sync pulses (see Fig.4). At the leading edge of the H-sync pulse on pin HS a 12-bit clock counter is started (nominal internal clock frequency is 48 MHz). The six horizontal timings (see Table 2) are countered as a number of internal clock pulses and stored in buffer registers. The contents of these buffer registers are copied to the I<sup>2</sup>C-bus data registers on every next leading edge of the V-sync pulse with the addition of LSBs (logic 0) for completing the full 2-byte data.

The measurements of HsWidth, Hperiod, Hfbstprt and Hfbstop in line 64 prevent wrong data capturing caused by post-equalizing sync pulses.

The minimum horizontal frequency is 12 kHz and Hperiod displays the full 12 bits. At 125 kHz, the shorter Hperiod will display 9 bits only but the resolution is still better than 0.25%.

Autosize IC for colour monitors

TDA4821P

**Table 2** Horizontal timing measurements

TIMING	BITS	CONDITIONS	REMARKS
HsWidth	8	trailing edge of pulse on pin HS	in line 64 only
Hperiod	12	next leading edge of pulse on pin HS	in line 64 only
Hfbstrt	12	leading edge of pulse on pin HFB	in line 64 only
Hfbstop	12	trailing edge of pulse on pin HFB	in line 64 only
HfstVid	12	first active video on pins VIN1, VIN2 or VIN3	in any line since last leading edge of pulse on pin VS
HlstVid	12	last active video on pins VIN1, VIN2 or VIN3	in any line since last leading edge of pulse on pin VS

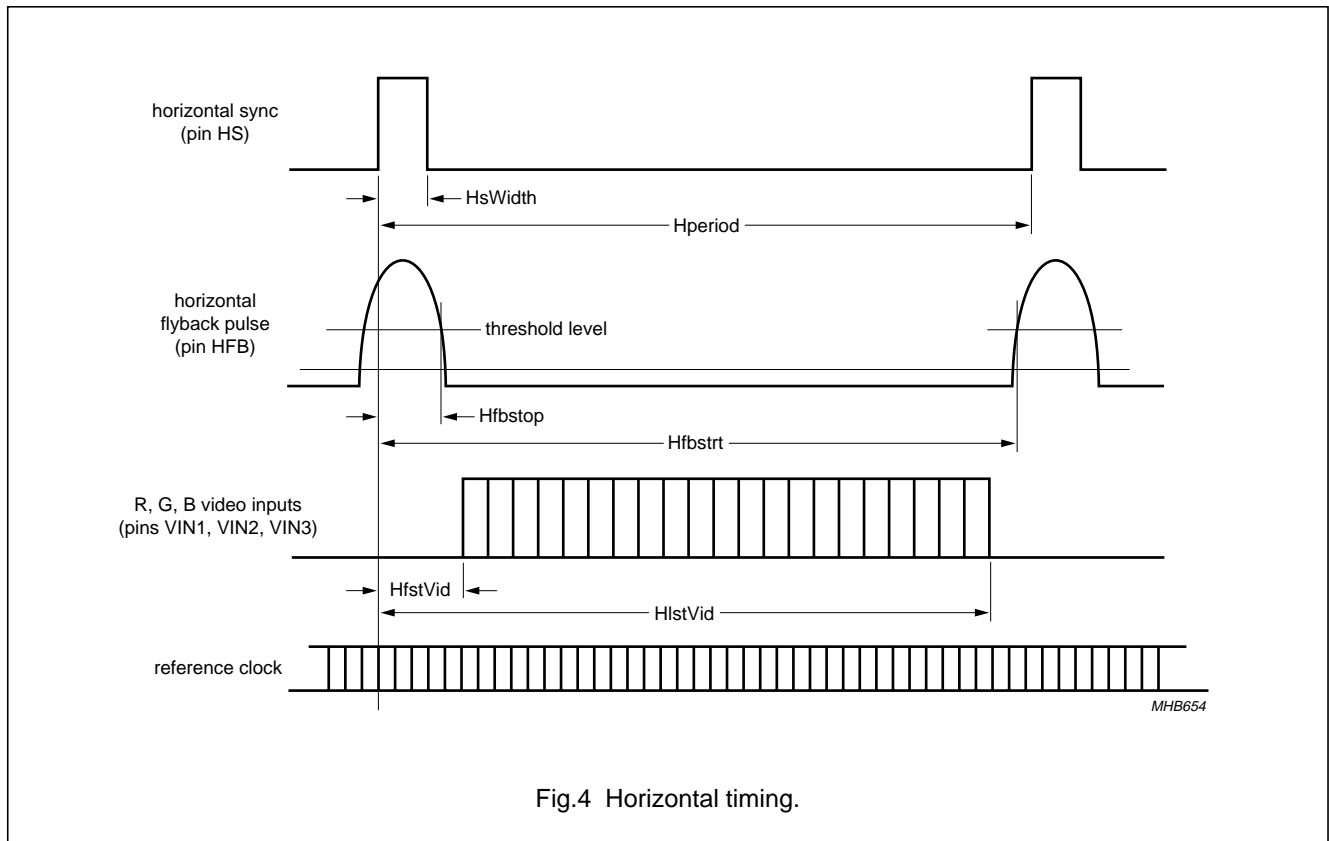

Fig.4 Horizontal timing.



# Autosize IC for colour monitors

# TDA4821P

### EXAMPLE OF A MEASUREMENT

On a 17-inch-screen the picture width is 320 mm. At a horizontal frequency of 70 kHz the active video is 11 μs. Thus, with a measuring clock of 48 MHz, there are 528 clock pulses. The start and end of the video with respect to the leading edge of the H-sync pulse can both be measured with an accuracy of one clock pulse. On

screen one clock pulse corresponds to  $\frac{320}{528} = 0.6$  mm.

An external microcontroller takes the measurements and after calculation the new settings will be downloaded to the deflection controller e.g. TDA4854, which has register steps corresponding to 0.4 mm on the screen. For this example, the positioning accuracy of the total auto-image concept will be in the range of: 0.6 + 0.4 = 1 mm.

Since the clock is asynchronous, repeated measurements may show jumping between two values. If the external microcontroller takes the average of a few measurements, the final accuracy will be improved and, as a result, the total accuracy (measurement accuracy and register step size) will be improved too.

### OTHER SYNC PULSE CONDITIONS

The IC needs both the H-sync and V-sync pulses on pins HS and VS respectively, for correct operation of the capture registers.

The initial contents of the I<sup>2</sup>C-bus registers are random. At least two V-sync pulses (one full vertical period) together with the normal H-sync pulses are needed before the contents become valid. Without H-sync pulses (but with V-sync pulses) the register contents will be random. Without V-sync pulses (but with H-sync pulses) the register contents will be random too and the same will happen if both H-sync and V-sync pulses are missing, again the register contents will be random.

In the event of the application of a composite sync signal to pin HS, the contents of the vertical capture registers may differ slightly from the actual line count, depending on the number of missing or additional H-sync pulses and/or equalizing pulses during the vertical blanking time.

### MISSING RGB VIDEO OR HORIZONTAL FLYBACK SIGNALS

If the RGB video signals or the horizontal flyback signal are below the threshold level these signals cannot be detected (missing signals). In that event the video and flyback registers will have the default values (see Table 3).

**Table 3** Register values for missing RGB video or horizontal flyback signals

CONDITIONS	REGISTER	VALUE
No R, G or B video signal	VfstVid	maximum: MSB = FF and LSB = F0
	VlstVid	zero: MSB = 0 and LSB = 0
	HfstVid	maximum: MSB = FF and LSB = F0
	HlstVid	zero: MSB = 0 and LSB = 0
No horizontal flyback signal	Hfbstrt	maximum: MSB = FF and LSB = F0
	Hfbstop	maximum: MSB = FF and LSB = F0

### I<sup>2</sup>C-bus interface and registers

The I<sup>2</sup>C-bus device address is 0111 010X, which means 74H for write and 75H for read.

The I<sup>2</sup>C-bus interface can handle standard I<sup>2</sup>C-bus features, including auto-increment in the read mode, so data byte by data byte can be read without sending a new subaddress each time. The interface can handle both 100 and 400 kHz I<sup>2</sup>C-bus standards. Pins SDA and SCL (5 V tolerable I/O) have digital filters, which remove all spikes smaller than 60 ns and the threshold levels on both pins are TTL compatible.

The contents of timing measurements, sync pulse polarity and the clock multiplication factor are stored in 22 registers of 8-bit length (see Table 4). All read registers are double buffered and written simultaneously on the leading edge of the V-sync pulse. That means that the data is stable for one complete field.

## Autosize IC for colour monitors

## TDA4821P

**Table 4** I<sup>2</sup>C-bus registers and their contents

SUBADDRESS REGISTER			R/W	MSB								LSB	
HEX	NAME	FUNCTION		D7	D6	D5	D4	D3	D2	D1	D0		
00	VsWidth (MSB)	V-sync width	R	b15	b14	b13	b12	b11	b10	b9	b8		
01	VsWidth (LSB)	V-sync width	R	0	0	0	0	0	0	0	0		
02	VfstVid (MSB)	start video after V-sync	R	b15	b14	b13	b12	b11	b10	b9	b8		
03	VfstVid (LSB)	start video after V-sync	R	b7	b6	b5	b4	0	0	0	0		
04	VlstVid (MSB)	stop video after V-sync	R	b15	b14	b13	b12	b11	b10	b9	b8		
05	VlstVid (LSB)	stop video after V-sync	R	b7	b6	b5	b4	0	0	0	0		
06	Vperiod (MSB)	V-sync cycle time	R	b15	b14	b13	b12	b11	b10	b9	b8		
07	Vperiod (LSB)	V-sync cycle time	R	b7	b6	b5	b4	0	0	0	0		
08	HsWidth (MSB)	H-sync width	R	b15	b14	b13	b12	b11	b10	b9	b8		
09	HsWidth (LSB)	H-sync width	R	0	0	0	0	0	0	0	0		
0A	HfstVid (MSB)	start video after H-sync	R	b15	b14	b13	b12	b11	b10	b9	b8		
0B	HfstVid (LSB)	start video after H-sync	R	b7	b6	b5	b4	0	0	0	0		
0C	HlstVid (MSB)	stop video after H-sync	R	b15	b14	b13	b12	b11	b10	b9	b8		
0D	HlstVid (LSB)	stop video after V-sync	R	b7	b6	b5	b4	0	0	0	0		
0E	Hperiod (MSB)	H-sync cycle time	R	b15	b14	b13	b12	b11	b10	b9	b8		
0F	Hperiod (LSB)	H-sync cycle time	R	b7	b6	b5	b4	0	0	0	0		
10	Hfbstrt (MSB)	start flyback after H-sync	R	b15	b14	b13	b12	b11	b10	b9	b8		
11	Hfbstrt (LSB)	start flyback after H-sync	R	b7	b6	b5	b4	0	0	0	0		
12	Hfbstop (MSB)	stop flyback after H-sync	R	b15	b14	b13	b12	b11	b10	b9	b8		
13	Hfbstop (LSB)	stop flyback after H-sync	R	b7	b6	b5	b4	0	0	0	0		
14	Sync polarities	sync polarities	R	0	0	0	0	0	0	Hpol	Vpol		
20	Mclk	clock multiplier	W	0	0	0	0	0	b2	b1	b0		

**Table 5** Description of the clock multiplier

REGISTER Mclk			CLOCK MULTIPLICATION FACTOR
b2	b1	b0	
0	0	1	1
0	1	0	2 (default after power-on)
0	1	1	3
1	0	0	4
1	0	1	5
1	1	0	6
1	1	1	7
0	0	0	8

## Autosize IC for colour monitors

## TDA4821P

**LIMITING VALUES**

In accordance with the Absolute Maximum Rating System (IEC 60134).

SYMBOL	PARAMETER	CONDITIONS	MIN.	MAX.	UNIT
$V_{DD(\text{core})}$	core supply voltage		-0.5	+4	V
$V_{DD(\text{I/O})}$	I/O supply voltage		-0.5	+4	V
$V_{DD(\text{PLL})}$	PLL supply voltage		-0.5	+4	V
$V_{i(n)}$	input voltage: on pins HS, VS, SCL and SDA on all other I/O pins		-0.5 -0.5	+5.5 $V_{DD} + 0.5$	V V
$I_{DD(\text{core})}$	core supply current		-	30	mA
$I_{DD(\text{I/O})}$	I/O supply current	external load on pin SDA	-	30	mA
$I_{DD(\text{PLL})}$	PLL supply current		-	1	mA
$I_o(\text{SDA})$	output current on pin SDA	external load	-	20	mA
$P_{\text{tot}}$	total power dissipation		-	200	mW
$T_{\text{stg}}$	storage temperature		-40	+125	°C
$T_{\text{amb}}$	ambient temperature		-20	+70	°C
$T_j$	junction temperature		-20	+125	°C
$V_{\text{es}}$	electrostatic handling voltage	note 1	-250	+250	V
		note 2	-4000	+4000	V

**Notes**

- Machine model: equivalent to discharging a 200 pF capacitor through a 0  $\Omega$  series resistor ('0  $\Omega$ ' is actually 0.75  $\mu\text{H} + 10 \Omega$ ).
- Human body model: equivalent to discharging a 100 pF capacitor through a 1500  $\Omega$  series resistor.

**THERMAL CHARACTERISTICS**

SYMBOL	PARAMETER	CONDITIONS	VALUE	UNIT
$R_{\text{th}(j-a)}$	thermal resistance from junction to ambient	in free air	80	K/W

## Autosize IC for colour monitors

## TDA4821P

**CHARACTERISTICS**

$V_{DD} = 3.3\text{ V}$ ;  $T_{amb} = 25\text{ °C}$ ; voltages measured with respect to ground (pins  $V_{SS}$ ); unless otherwise specified.

SYMBOL	PARAMETER	CONDITIONS	MIN.	TYP.	MAX.	UNIT
<b>Supplies</b>						
$V_{DD(\text{core})}$	core supply voltage (pin 15)		3	3.3	3.6	V
$V_{DD(\text{I/O})}$	I/O supply voltage (pin 6)		3	3.3	3.6	V
$V_{DD(\text{PLL})}$	PLL supply voltage (pin 3)		3	3.3	3.6	V
$I_{DD(\text{core})}$	core supply current (pin 15)	$f_{\text{clk}(\text{int})} = 48\text{ MHz}$	–	10	14	mA
		$f_{\text{clk}(\text{int})} = 24\text{ MHz}$	–	6	8	mA
$I_{DD(\text{I/O})}$	I/O supply current (pin 6)	no load on digital output pins	–	–	300	$\mu\text{A}$
$I_{DD(\text{PLL})}$	PLL supply current (pin 3)		–	400	800	$\mu\text{A}$
$P_{\text{tot}}$	total power dissipation		–	–	100	mW
<b>RGB input stage</b>						
$V_{\text{VIN}1}$	video channel 1 input voltage (pin 1)	AC-coupled with 10 nF	0	–	$V_{DD} - 0.5$	V
$V_{\text{VIN}2}$	video channel 2 input voltage (pin 2)	AC-coupled with 10 nF	0	–	$V_{DD} - 0.5$	V
$V_{\text{VIN}3}$	video channel 3 input voltage (pin 19)	AC-coupled with 10 nF	0	–	$V_{DD} - 0.5$	V
$V_{\text{CLP}}$	clamping active input voltage (pin 17)		0	–	$V_{DD}$	V
$V_{\text{clamp}(\text{ref})}$	default clamping level for video channel inputs (pins 1, 2 and 19)	internal default value	360	400	440	mV
$V_{\text{clamp}(\text{video})}$	clamping voltage range for video channel inputs (pins 1, 2 and 19)	externally adjustable range	100	400	440	mV
$V_{\text{slice}}$	slicing voltage for video comparators		450	500	550	mV
$t_{\text{d}(\text{video})}$	video comparator delay time	$V_{\text{VIN}} = V_{\text{slice}} + 30\text{ mV}$	–	10	25	ns
$I_{\text{clamp}}$	clamping current	$V_{\text{clamp}} = 400\text{ mV}$ ; clamp = HIGH	–	–	10	mA
$I_{\text{LL}(\text{video})}$	video input leakage current	clamp = LOW	–	–	1	$\mu\text{A}$
$V_{\text{clamp}}$	clamping level voltage (pin 20)	internal default value	380	400	420	mV
$V_{\text{clamp}(\text{adj})}$	adjustable clamping level voltage range (pin 20)	externally adjustable range	0	–	420	mV
$C_{\text{LEV}(\text{min})}$	minimum capacitance at LEV (pin 20)		1	10	–	nF
$V_{\text{th}(\text{H})}$	clamping active threshold voltage (pin 17)	rising edge (hysteresis input)	1.3	–	1.9	V
$V_{\text{th}(\text{L})}$	clamping inactive threshold voltage (pin 17)	falling edge (hysteresis input)	0.9	–	1.35	V
$t_{\text{W}(\text{clamp})}$	clamping pulse width (pin 17)	video inputs AC-coupled with 10 nF	300	–	–	ns

## Autosize IC for colour monitors

## TDA4821P

SYMBOL	PARAMETER	CONDITIONS	MIN.	TYP.	MAX.	UNIT
<b>Clock PLL</b>						
$f_{\text{clk}(\text{ext})}$	external input clock frequency (pin 4)		4	–	24	MHz
$f_{\text{clk}(\text{int})}$	internal clock frequency	$f_{\text{clk}(\text{int})} = f_{\text{clk}(\text{ext})} \times M_{\text{clk}}$	18	48	72	MHz
$M_{\text{clk}}$	clock multiplication factor	adjustable via I <sup>2</sup> C-bus	1	–	8	–
		default value after power-on; I <sup>2</sup> C-bus not active	–	2	–	–
$t_{\text{res}(\text{h})}$	time resolution for horizontal measurements	without external averaging methods:				
		$f_{\text{clk}(\text{int})} = 48 \text{ MHz}$ $f_{\text{clk}(\text{int})} = 72 \text{ MHz}$	– –	20 14	– –	ns ns
$V_{\text{i}(\text{CLK})}$	input voltage on pin CLK (pin 4)		0	–	$V_{\text{DD}}$	V
<b>Digital inputs and outputs</b>						
INPUT PINS HS, VS, POR AND HFB (PINS 7, 8, 9 AND 10)						
$V_{\text{IL}}$	LOW-level input voltage		–	–	0.8	V
$V_{\text{IH}}$	HIGH-level input voltage		2	–	–	V
$I_{\text{LI}}$	input leakage current		–	–	1	$\mu\text{A}$
$V_{\text{i}(9,10)}$	input voltage on pins 9 and 10		0	–	$V_{\text{DD}}$	V
$V_{\text{i}(7,8)}$	input voltage on pins 7 and 8		0	–	5.25	V
$t_{\text{W}}$	pulse width of input signals on pins 7, 8 and 10	$f_{\text{clk}(\text{int})} = 48 \text{ MHz}$	100	–	–	ns
I <sup>2</sup> C-BUS INPUT/OUTPUT PINS SCL AND SDA (PINS 12 AND 13)						
$V_{\text{IL}}$	LOW-level input voltage		–	–	0.8	V
$V_{\text{IH}}$	HIGH-level input voltage		2	–	–	V
$I_{\text{LI}}$	input leakage current		–	–	1	$\mu\text{A}$
$V_{\text{OL}}$	LOW-level output voltage	$I_{\text{o}(13)} = 3 \text{ mA}$	–	–	0.4	V
$V_{\text{OH}}$	HIGH-level output voltage	$I_{\text{o}(13)} = -3 \text{ mA}$	2.4	–	–	V
$V_{\text{i}(12,13)}$	input voltage on pins 12 and 13	external pull-up resistor to 5 V supply	0	–	5.25	V
$I_{\text{o}(13)}$	output current on pin 13	external load	–	–	3	mA
$f_{\text{SCL}}$	I <sup>2</sup> C-bus serial clock frequency		–	–	400	kHz

Autosize IC for colour monitors

TDA4821P

APPLICATION INFORMATION

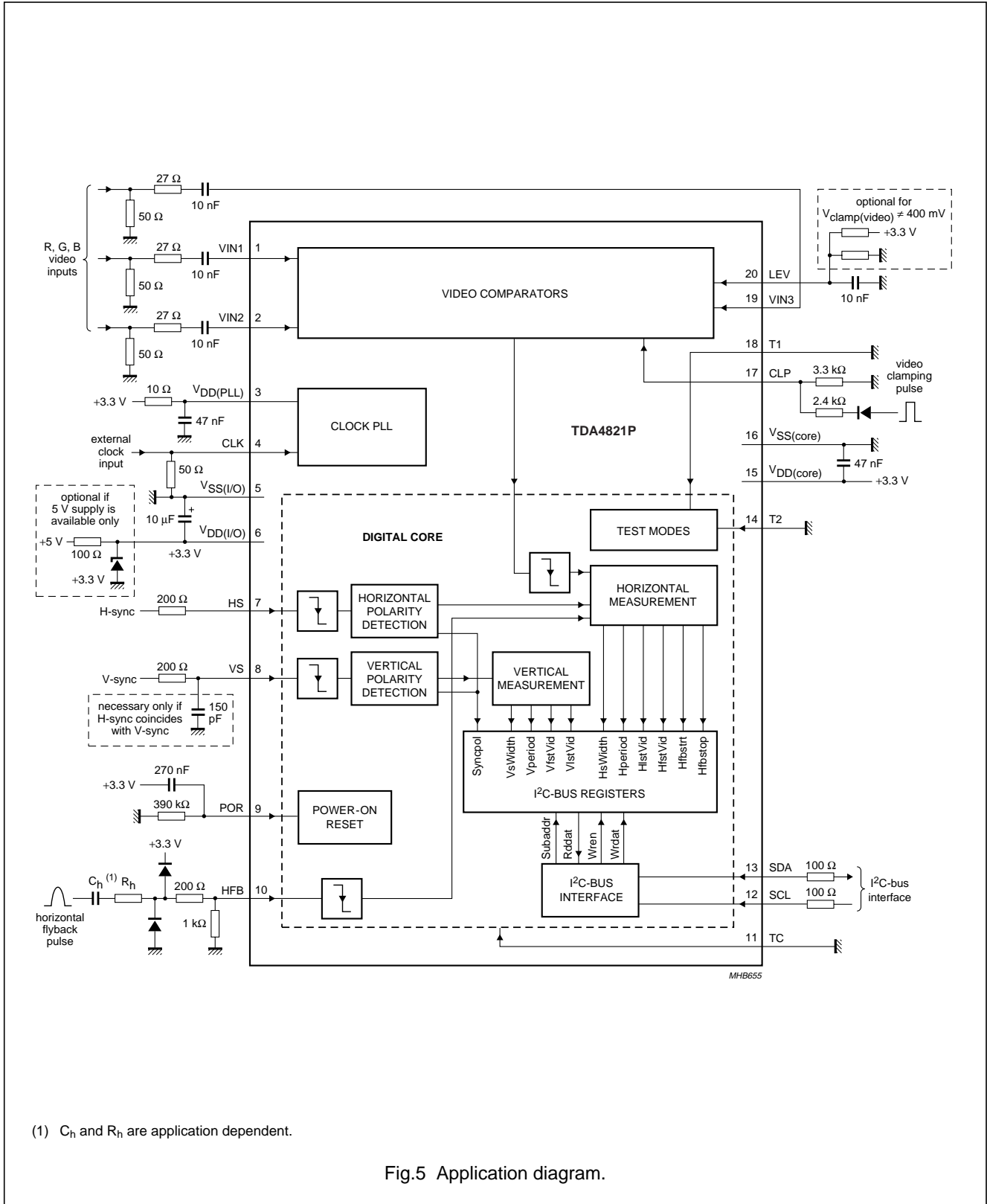

Fig.5 Application diagram.

Autosize IC for colour monitors

TDA4821P

PACKAGE OUTLINE

DIP20: plastic dual in-line package; 20 leads (300 mil)

SOT146-1

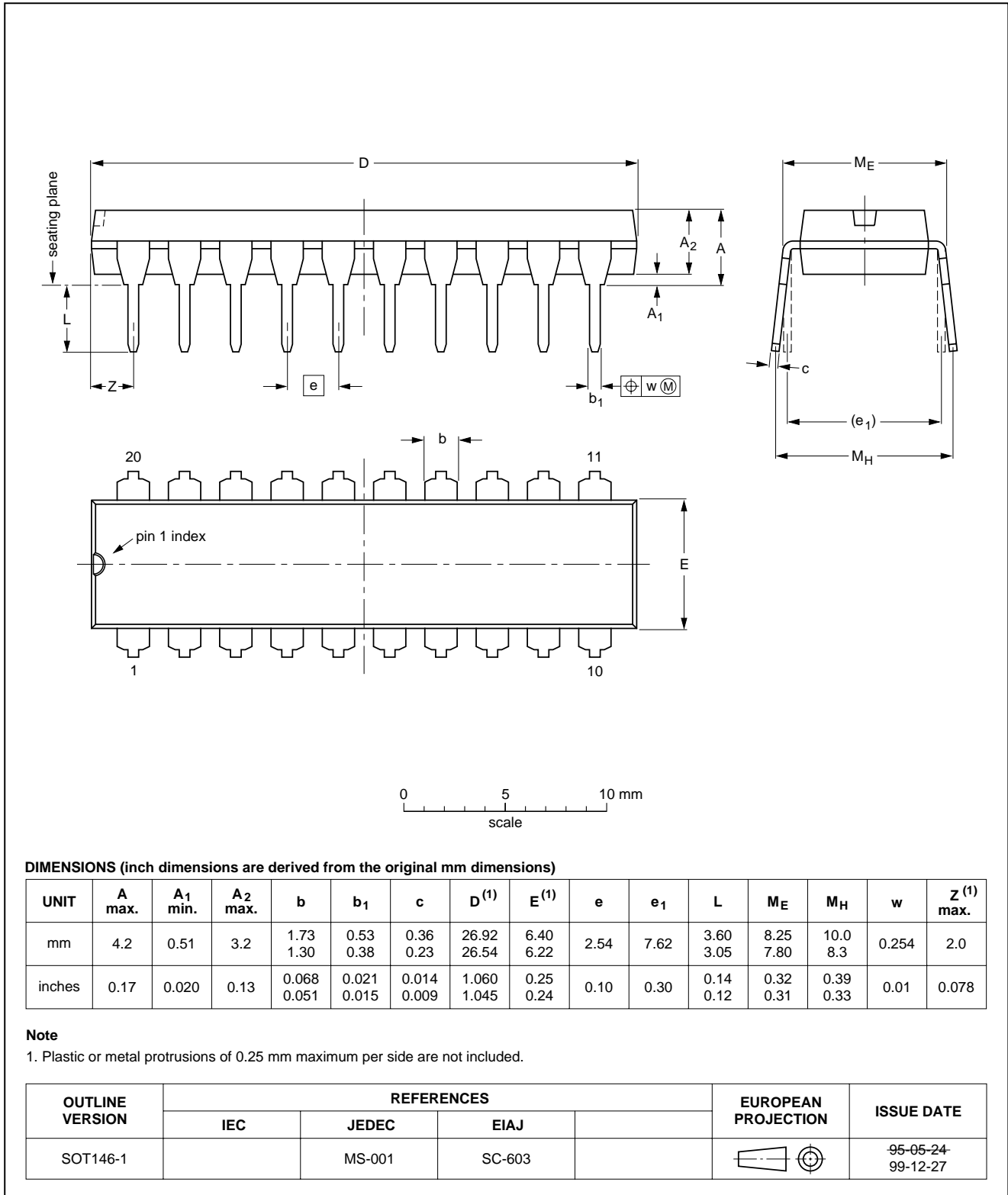

## Autosize IC for colour monitors

## TDA4821P

**SOLDERING****Introduction to soldering through-hole mount packages**

This text gives a brief insight to wave, dip and manual soldering. A more in-depth account of soldering ICs can be found in our *"Data Handbook IC26; Integrated Circuit Packages"* (document order number 9398 652 90011).

Wave soldering is the preferred method for mounting of through-hole mount IC packages on a printed-circuit board.

**Soldering by dipping or by solder wave**

The maximum permissible temperature of the solder is 260 °C; solder at this temperature must not be in contact with the joints for more than 5 seconds.

The total contact time of successive solder waves must not exceed 5 seconds.

The device may be mounted up to the seating plane, but the temperature of the plastic body must not exceed the specified maximum storage temperature ( $T_{stg(max)}$ ). If the printed-circuit board has been pre-heated, forced cooling may be necessary immediately after soldering to keep the temperature within the permissible limit.

**Manual soldering**

Apply the soldering iron (24 V or less) to the lead(s) of the package, either below the seating plane or not more than 2 mm above it. If the temperature of the soldering iron bit is less than 300 °C it may remain in contact for up to 10 seconds. If the bit temperature is between 300 and 400 °C, contact may be up to 5 seconds.

**Suitability of through-hole mount IC packages for dipping and wave soldering methods**

PACKAGE	SOLDERING METHOD	
	DIPPING	WAVE
DBS, DIP, HDIP, SDIP, SIL	suitable	suitable <sup>(1)</sup>

**Note**

- For SDIP packages, the longitudinal axis must be parallel to the transport direction of the printed-circuit board.



## Autosize IC for colour monitors

TDA4821P

**DEFINITIONS**

<b>Data sheet status</b>	
Objective specification	This data sheet contains target or goal specifications for product development.
Preliminary specification	This data sheet contains preliminary data; supplementary data may be published later.
Product specification	This data sheet contains final product specifications.
<b>Limiting values</b>	
Limiting values given are in accordance with the Absolute Maximum Rating System (IEC 134). Stress above one or more of the limiting values may cause permanent damage to the device. These are stress ratings only and operation of the device at these or at any other conditions above those given in the Characteristics sections of the specification is not implied. Exposure to limiting values for extended periods may affect device reliability.	
<b>Application information</b>	
Where application information is given, it is advisory and does not form part of the specification.	

**LIFE SUPPORT APPLICATIONS**

These products are not designed for use in life support appliances, devices, or systems where malfunction of these products can reasonably be expected to result in personal injury. Philips customers using or selling these products for use in such applications do so at their own risk and agree to fully indemnify Philips for any damages resulting from such improper use or sale.

**PURCHASE OF PHILIPS I<sup>2</sup>C COMPONENTS**

Purchase of Philips I<sup>2</sup>C components conveys a license under the Philips' I<sup>2</sup>C patent to use the components in the I<sup>2</sup>C system provided the system conforms to the I<sup>2</sup>C specification defined by Philips. This specification can be ordered using the code 9398 393 40011.

Autosize IC for colour monitors

TDA4821P

---

**NOTES**

Autosize IC for colour monitors

TDA4821P

---

**NOTES**

# Philips Semiconductors – a worldwide company

**Argentina:** see South America

**Australia:** 3 Figtree Drive, HOME BUSH, NSW 2140,  
Tel. +61 2 9704 8141, Fax. +61 2 9704 8139

**Austria:** Computerstr. 6, A-1101 WIEN, P.O. Box 213,  
Tel. +43 1 60 101 1248, Fax. +43 1 60 101 1210

**Belarus:** Hotel Minsk Business Center, Bld. 3, r. 1211, Volodarski Str. 6,  
220050 MINSK, Tel. +375 172 20 0733, Fax. +375 172 20 0773

**Belgium:** see The Netherlands

**Brazil:** see South America

**Bulgaria:** Philips Bulgaria Ltd., Energoproject, 15th floor,  
51 James Bourchier Blvd., 1407 SOFIA,  
Tel. +359 2 68 9211, Fax. +359 2 68 9102

**Canada:** PHILIPS SEMICONDUCTORS/COMPONENTS,  
Tel. +1 800 234 7381, Fax. +1 800 943 0087

**China/Hong Kong:** 501 Hong Kong Industrial Technology Centre,  
72 Tat Chee Avenue, Kowloon Tong, HONG KONG,  
Tel. +852 2319 7888, Fax. +852 2319 7700

**Colombia:** see South America

**Czech Republic:** see Austria

**Denmark:** Sydhavnsgade 23, 1780 COPENHAGEN V,  
Tel. +45 33 29 3333, Fax. +45 33 29 3905

**Finland:** Sinikalliontie 3, FIN-02630 ESPOO,  
Tel. +358 9 615 800, Fax. +358 9 6158 0920

**France:** 51 Rue Carnot, BP317, 92156 SURESNES Cedex,  
Tel. +33 1 4099 6161, Fax. +33 1 4099 6427

**Germany:** Hammerbrookstraße 69, D-20097 HAMBURG,  
Tel. +49 40 2353 60, Fax. +49 40 2353 6300

**Hungary:** see Austria

**India:** Philips INDIA Ltd, Band Box Building, 2nd floor,  
254-D, Dr. Annie Besant Road, Worli, MUMBAI 400 025,  
Tel. +91 22 493 8541, Fax. +91 22 493 0966

**Indonesia:** PT Philips Development Corporation, Semiconductors Division,  
Gedung Philips, Jl. Buncit Raya Kav.99-100, JAKARTA 12510,  
Tel. +62 21 794 0040 ext. 2501, Fax. +62 21 794 0080

**Ireland:** Newstead, Clonskeagh, DUBLIN 14,  
Tel. +353 1 7640 000, Fax. +353 1 7640 200

**Israel:** RAPAC Electronics, 7 Kehilat Saloniki St, PO Box 18053,  
TEL AVIV 61180, Tel. +972 3 645 0444, Fax. +972 3 649 1007

**Italy:** PHILIPS SEMICONDUCTORS, Via Casati, 23 - 20052 MONZA (MI),  
Tel. +39 039 203 6838, Fax +39 039 203 6800

**Japan:** Philips Bldg 13-37, Kohnan 2-chome, Minato-ku,  
TOKYO 108-8507, Tel. +81 3 3740 5130, Fax. +81 3 3740 5057

**Korea:** Philips House, 260-199 Itaewon-dong, Yongsan-ku, SEOUL,  
Tel. +82 2 709 1412, Fax. +82 2 709 1415

**Malaysia:** No. 76 Jalan Universiti, 46200 PETALING JAYA, SELANGOR,  
Tel. +60 3 750 5214, Fax. +60 3 757 4880

**Mexico:** 5900 Gateway East, Suite 200, EL PASO, TEXAS 79905,  
Tel. +9-5 800 234 7381, Fax +9-5 800 943 0087

**Middle East:** see Italy

**Netherlands:** Postbus 90050, 5600 PB EINDHOVEN, Bldg. VB,  
Tel. +31 40 27 82785, Fax. +31 40 27 88399

**New Zealand:** 2 Wagener Place, C.P.O. Box 1041, AUCKLAND,  
Tel. +64 9 849 4160, Fax. +64 9 849 7811

**Norway:** Box 1, Manglerud 0612, OSLO,  
Tel. +47 22 74 8000, Fax. +47 22 74 8341

**Pakistan:** see Singapore

**Philippines:** Philips Semiconductors Philippines Inc.,  
106 Valero St. Salcedo Village, P.O. Box 2108 MCC, MAKATI,  
Metro MANILA, Tel. +63 2 816 6380, Fax. +63 2 817 3474

**Poland:** Al.Jerozolimskie 195 B, 02-222 WARSAW,  
Tel. +48 22 5710 000, Fax. +48 22 5710 001

**Portugal:** see Spain

**Romania:** see Italy

**Russia:** Philips Russia, Ul. Usatcheva 35A, 119048 MOSCOW,  
Tel. +7 095 755 6918, Fax. +7 095 755 6919

**Singapore:** Lorong 1, Toa Payoh, SINGAPORE 319762,  
Tel. +65 350 2538, Fax. +65 251 6500

**Slovakia:** see Austria

**Slovenia:** see Italy

**South Africa:** S.A. PHILIPS Pty Ltd., 195-215 Main Road Martindale,  
2092 JOHANNESBURG, P.O. Box 58088 Newville 2114,  
Tel. +27 11 471 5401, Fax. +27 11 471 5398

**South America:** Al. Vicente Pinzon, 173, 6th floor,  
04547-130 SÃO PAULO, SP, Brazil,  
Tel. +55 11 821 2333, Fax. +55 11 821 2382

**Spain:** Balmes 22, 08007 BARCELONA,  
Tel. +34 93 301 6312, Fax. +34 93 301 4107

**Sweden:** Kottbygatan 7, Akalla, S-16485 STOCKHOLM,  
Tel. +46 8 5985 2000, Fax. +46 8 5985 2745

**Switzerland:** Allmendstrasse 140, CH-8027 ZÜRICH,  
Tel. +41 1 488 2741 Fax. +41 1 488 3263

**Taiwan:** Philips Semiconductors, 6F, No. 96, Chien Kuo N. Rd., Sec. 1,  
TAIPEI, Taiwan Tel. +886 2 2134 2886, Fax. +886 2 2134 2874

**Thailand:** PHILIPS ELECTRONICS (THAILAND) Ltd.,  
209/2 Sanpavuth-Bangna Road Prakanong, BANGKOK 10260,  
Tel. +66 2 745 4090, Fax. +66 2 398 0793

**Turkey:** Yukari Dudullu, Org. San. Blg., 2.Cad. Nr. 28 81260 Umraniye,  
ISTANBUL, Tel. +90 216 522 1500, Fax. +90 216 522 1813

**Ukraine:** PHILIPS UKRAINE, 4 Patrice Lumumba str., Building B, Floor 7,  
252042 KIEV, Tel. +380 44 264 2776, Fax. +380 44 268 0461

**United Kingdom:** Philips Semiconductors Ltd., 276 Bath Road, Hayes,  
MIDDLESEX UB3 5BX, Tel. +44 208 730 5000, Fax. +44 208 754 8421

**United States:** 811 East Arques Avenue, SUNNYVALE, CA 94088-3409,  
Tel. +1 800 234 7381, Fax. +1 800 943 0087

**Uruguay:** see South America

**Vietnam:** see Singapore

**Yugoslavia:** PHILIPS, Trg N. Pasica 5/v, 11000 BEOGRAD,  
Tel. +381 11 3341 299, Fax.+381 11 3342 553

**For all other countries apply to:** Philips Semiconductors,  
International Marketing & Sales Communications, Building BE-p, P.O. Box 218,  
5600 MD EINDHOVEN, The Netherlands, Fax. +31 40 27 24825

**Internet:** <http://www.semiconductors.philips.com>

© Philips Electronics N.V. 2000

SCA 69

All rights are reserved. Reproduction in whole or in part is prohibited without the prior written consent of the copyright owner.

The information presented in this document does not form part of any quotation or contract, is believed to be accurate and reliable and may be changed without notice. No liability will be accepted by the publisher for any consequence of its use. Publication thereof does not convey nor imply any license under patent- or other industrial or intellectual property rights.

Printed in The Netherlands

753504/01/pp20

Date of release: 2000 Feb 09

Document order number: 9397 750 06572

*Let's make things better.*

**Philips**  
Semiconductors



**PHILIPS**