

# DATA SHEET

## **TDA4672**

**Picture Signal Improvement (PSI)  
circuit with enhanced peaking  
function**

Product specification  
Supersedes data of August 1993  
File under Integrated Circuits, IC02

1996 Dec 11

## Picture Signal Improvement (PSI) circuit with enhanced peaking function

TDA4672

### FEATURES

- Luminance signal delay from 20 ns to 1 100 ns (minimum step 45 ns)
- Selectable luminance signal peaking with symmetrical overshoots
- Selectable 2.6 or 5 MHz peaking centre frequency and degree of peaking from -6 dB to +9 dB in 16 steps of 1 dB each
- Selectable noise reduction by coring
- Selectable 5 or 12 V sandcastle input voltage
- All controls selected via the I<sup>2</sup>C-bus
- Timing pulse generation for clamping and delay time control synchronized by sandcastle pulse
- Automatic luminance signal delay correction using a control loop
- Luminance input signal clamping with coupling capacitor
- 4.5 to +8.8 V supply voltage
- Minimum of external components.



### GENERAL DESCRIPTION

The TDA4672 delays the luminance signal. The luminance signal can also be improved by peaking and noise reduction (coring).

### QUICK REFERENCE DATA

SYMBOL	PARAMETER	MIN.	TYP.	MAX.	UNIT
V <sub>P</sub>	supply voltage (pin 1)	4.5	5	8.8	V
I <sub>P(tot)</sub>	total supply current	26	37	46	mA
t <sub>d(Y)</sub>	Y signal delay time	20	–	1 130	ns
V <sub>i(Y)(p-p)</sub>	composite Y input signal (peak-to-peak value, pin 16)	–	450	640	mV
G <sub>Y</sub>	voltage gain of Y channel	–	-1	–	dB
T <sub>amb</sub>	operating ambient temperature	0	–	70	°C

### ORDERING INFORMATION

TYPE NUMBER	PACKAGE		
	NAME	DESCRIPTION	VERSION
TDA4672	DIP18	plastic dual in-line package; 18 leads (300 mil)	SOT102-1

Picture Signal Improvement (PSI) circuit  
with enhanced peaking function

TDA4672

BLOCK DIAGRAM

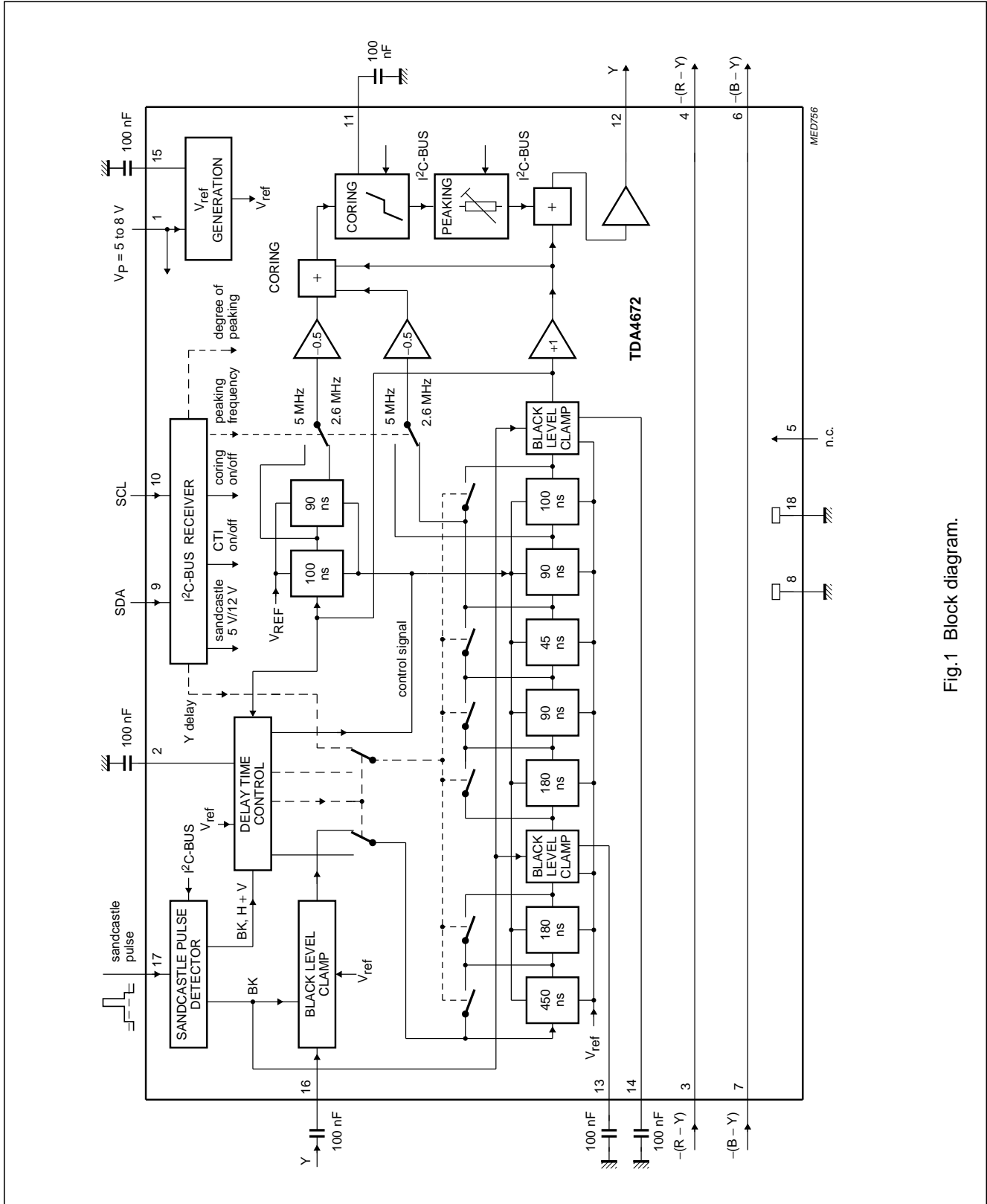

Fig.1 Block diagram.

# Picture Signal Improvement (PSI) circuit with enhanced peaking function

TDA4672

## PINNING

SYMBOL	PIN	DESCRIPTION
$V_P$	1	positive supply voltage
$C_{DL}$	2	capacitor of delay time control
$V_{i(R-Y)}$	3	$\pm(R - Y)$ colour-difference input signal; note 1
$V_{o(R-Y)}$	4	$\pm(R - Y)$ colour-difference output signal; note 1
n.c.	5	not connected
$V_{o(B-Y)}$	6	$\pm(B - Y)$ colour-difference output signal; note 2
$V_{i(B-Y)}$	7	$\pm(B - Y)$ colour-difference input signal; note 2
GND2	8	ground 2 (0 V)
SDA	9	I <sup>2</sup> C-bus serial data input/output
SCL	10	I <sup>2</sup> C-bus serial clock input
$C_{COR}$	11	coring capacitor
$V_{oY}$	12	delayed luminance output signal
$C_{CLP1}$	13	black level clamping capacitor 1
$C_{CLP2}$	14	black level clamping capacitor 2
$C_{ref}$	15	capacitor of reference voltage
$V_{iY}$	16	luminance input signal
SAND	17	sandcastle pulse input
GND1	18	ground 1 (0 V)

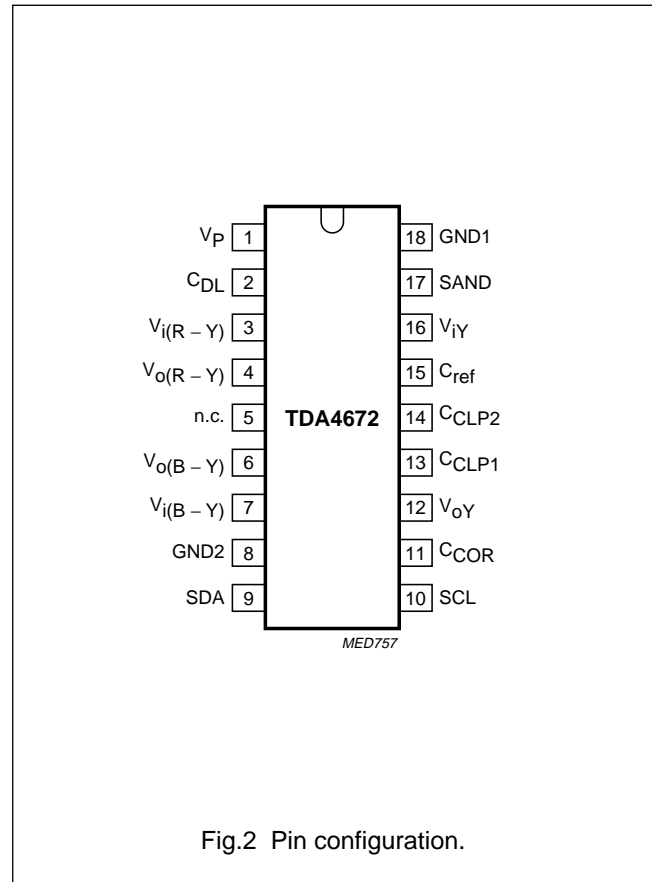

Fig.2 Pin configuration.

## Notes

1. Pin 3 is connected directly to pin 4.
2. Pin 7 is connected directly to pin 6.

---

## Picture Signal Improvement (PSI) circuit with enhanced peaking function

---

TDA4672

### FUNCTIONAL DESCRIPTION

The TDA4672 contains luminance signal processing. The luminance signal section comprises a variable, integrated luminance delay line with luminance signal peaking and noise reduction by coring.

All functions and parameters are controlled via the I<sup>2</sup>C-bus.

#### Y-signal path

The video and blanking signal is AC-coupled to the input pin 16. Its black porch is clamped to a DC reference voltage to ensure the correct operating range of the luminance delay stage.

The luminance delay line consists of all-pass filter sections with delay times of 45, 90, 100, 180 and 450 ns (see Fig.1). The luminance signal delay is controlled via the I<sup>2</sup>C-bus in steps of 45 ns in the range of 20 to 1100 ns, this ensures that the maximum delay difference between the luminance and colour-difference signals is  $\pm 22.5$  ns.

An automatic luminance delay time adjustment in an internal control loop (with the horizontal frequency as a reference) is used to correct changes in the delay time, due to component tolerances. The control loop is automatically enabled between the burst key pulses of lines 16 (330) and 17 (331) during the vertical blanking interval. The control voltage is stored in the capacitor C<sub>DL</sub> connected to pin 2.

The peaking section uses a transversal filter circuit with selectable centre frequencies of 2.6 and 5.0 MHz.

It provides selectable degrees of peaking from -6 to +9 dB and noise reduction by coring, which attenuates the high-frequency noise introduced by peaking.

The output buffer stage ensures a low-ohmic Video Blanking Synchronization (VBS) output signal on pin 12 (<160  $\Omega$ ). The gain of the luminance signal path from pin 16 to pin 12 is unity.

An oscillation signal of the delay time control loop is present on output pin 12 instead of the VBS signal. It is present during the vertical blanking interval of the burst key pulses in lines 16 (330) to 18 (332). This sync should not be applied for synchronization.

#### Colour-difference signal paths

The colour-difference input signals (on pins 3 and 7) are connected directly to the output pins.

This is for compatibility with other Philips Semiconductors PSI-circuits.

# Picture Signal Improvement (PSI) circuit with enhanced peaking function

TDA4672

## LIMITING VALUES

In accordance with the Absolute Maximum Rating System (IEC 134). GND1 and GND2 are connected together.

SYMBOL	PARAMETER	CONDITIONS	MIN.	MAX.	UNIT
$V_P$	supply voltage (pin 1)		0	8.8	V
$V_I$	input voltage (pins 2 to 7 and pins 11 to 16)		-0.1	$V_P$	V
$V_{9,10}$	input voltage at pins 9 and 10		-0.1	+8.8	V
$V_{17}$	input voltage at pin 17		-0.1	+12	V
$I_{8-18}$	current between pins 8 and 18		-	$\pm 20$	mA
$I_{3-4}$	current between pins 3 and 4		-	$\pm 4$	mA
$I_{6-7}$	current between pins 6 and 7		-	$\pm 4$	mA
$P_{tot}$	total power dissipation		0	0.97	W
$T_{stg}$	storage temperature		-25	+150	°C
$T_{amb}$	operating ambient temperature		0	70	°C
$V_{ESD}$	electrostatic handling for pin 17	note 1	-	+250	V
			-	-500	V
	for other pins		-	$\pm 500$	V

### Note

- Equivalent to discharging a 200 pF capacitor through a 0  $\Omega$  series resistor.

## THERMAL CHARACTERISTICS

SYMBOL	PARAMETER	VALUE	UNIT
$R_{th\ j-a}$	thermal resistance from junction to ambient in free air	82	K/W

## CHARACTERISTICS

$V_P = 5$  V; nominal video amplitude  $V_{VB} = 315$  mV;  $t_H = 64$   $\mu$ s;  $t_{BK} = 4$   $\mu$ s (burst key);  $T_{amb} = 25$  °C and measurements taken in Fig.4; unless otherwise specified.

SYMBOL	PARAMETER	CONDITIONS	MIN.	TYP.	MAX.	UNIT
$V_P$	supply voltage (pin 1)		4.5	5	8.8	V
$I_{P(tot)}$	total supply current		26	37	46	mA
<b>Y-signal path</b>						
$V_{i(Y)(p-p)}$	VBS input signal on pin 16 (peak-to-peak value)		-	450	640	mV
$V_{16}$	black level clamping voltage		-	3.1	-	V
$I_{16}$	input current	during clamping	$\pm 95$	-	$\pm 190$	$\mu$ A
		outside clamping	-	-	$\pm 0.1$	$\mu$ A
$R_{16}$	input resistance	outside clamping	5	-	-	M $\Omega$
$C_{16}$	input capacitance		-	3	10	pF
$t_{d(Y)(max)}$	maximum Y delay time	set via I <sup>2</sup> C-bus	1070	1100	1130	ns
$t_{d(Y)(min)}$	minimum Y delay time	set via I <sup>2</sup> C-bus	-	20	-	ns

# Picture Signal Improvement (PSI) circuit with enhanced peaking function

TDA4672

SYMBOL	PARAMETER	CONDITIONS	MIN.	TYP.	MAX.	UNIT
$\Delta t_{d(Y)}$	minimum delay step	set via I <sup>2</sup> C-bus	40	45	50	ns
	group delay time difference	f = 0.5 to 5 MHz; maximum delay	–	0	±25	ns
$t_{d(\text{peak})}$	minimum delay time for peaking		185	215	245	ns
$G_Y$	VBS signal gain measured on output pin 12 (composite signal, peak-to-peak value)	$V_{12}/V_{16}$ ; f = 500 kHz; maximum delay	–2	–1	0	dB
$I_{12}$	output current (emitter-follower with constant current source)	source current	–1	–	–	mA
		sink current	0.4	–	–	mA
$R_{12}$	output resistance		–	–	160	$\Omega$
f	frequency response for	maximum delay				
		f = 0.5 to 3 MHz	–2	–1	0	dB
		f = 0.5 to 5 MHz	–4	–3	–1	dB
LIN	signal linearity for	$\alpha_{\text{min}}/\alpha_{\text{max}}$ ; note 1				
	video contents of 315 mV (p-p)	$V_{\text{VBS}} = 450$ mV (p-p)	0.85	–	–	–
	video contents of 450 mV (p-p)	$V_{\text{VBS}} = 640$ mV (p-p)	0.60	–	–	–
<b>Luminance peaking, selected via I<sup>2</sup>C-bus</b>						
$f_{\text{peak}}$	peaking frequency	$f_{C1}$ ; LCF-bit = 0	4.5	5	5.5	MHz
		$f_{C2}$ ; LCF-bit = 1	2.3	2.6	2.9	MHz
$V_{\text{peak}}$	peaking amplitude for grade of peaking ( $f_C$ amplitude over 0.5 MHz amplitude) selectable values from to each step	Y delay = 215 ns; peaking delay only				
			–	–6	–	dB
			–	+9	–	dB
			–	1	–	dB
	no limitation of peaking		–	–	–	%
$V_{n(\text{rms})}$	noise voltage on pin 12 (RMS value)	without peaking; f = 0 to 5 MHz	–	–	1	mV
COR	coring of peaking (coring part referred to 315 mV)	COR-bit = 1	–	20	–	%

# Picture Signal Improvement (PSI) circuit with enhanced peaking function

TDA4672

SYMBOL	PARAMETER	CONDITIONS	MIN.	TYP.	MAX.	UNIT
<b>Sandcastle pulse, input voltage selectable via I<sup>2</sup>C-bus</b>						
V <sub>17</sub>	input voltage threshold for H and V sync	SC5-bit = 0 (+12 V)	1.1	1.5	1.9	V
	input voltage threshold for burst	SC5-bit = 0 (+12 V)	5.5	6.5	7.5	V
	input voltage threshold for H and V sync	SC5-bit = 1 (+5 V)	1.1	1.5	1.9	V
	input voltage threshold for burst	SC5-bit = 1 (+5 V)	3.0	3.5	4.0	V
R <sub>17</sub>	input resistance	+12 V input level	30	40	50	kΩ
		+5 V input level	15	20	25	kΩ
C <sub>17</sub>	input capacitance		–	4	8	pF
t <sub>BK</sub>	burst key pulse width		3.0	4.0	4.6	μs
t <sub>d</sub>	leading edge delay for clamping pulse	referenced to t <sub>BK</sub>	–	1	–	μs
n <sub>p</sub>	number of required burst key pulses vertical blanking interval	note 2	4	–	31	–
<b>I<sup>2</sup>C-bus control, SDA and SCL</b>						
V <sub>IH</sub>	HIGH level input voltage on pins 9 and 10		3	–	5	V
V <sub>IL</sub>	LOW level input voltage on pins 9 and 10		0	–	1.5	V
I <sub>9,10</sub>	input current on pins 9 and 10		–	–	±10	μA
V <sub>o(ACK)</sub>	output voltage at acknowledge on pin 9	I <sub>o(ACK)</sub> = 3 mA	–	–	0.4	V
I <sub>o(ACK)</sub>	output current at acknowledge on pin 9	sink current	3	–	–	mA

**Notes**

1.  $\alpha_{\min}$ : minimum differential voltage gain of the luminance video signal;  
 $\alpha_{\max}$ : maximum differential voltage gain of the luminance video signal.
2. A number of more than 31 burst key pulses repeats the counter cycle of delay time control.



# Picture Signal Improvement (PSI) circuit with enhanced peaking function

TDA4672

## I<sup>2</sup>C-BUS FORMAT

S <sup>(1)</sup>	SLAVE ADDRESS <sup>(2)</sup>	ACK <sup>(3)</sup>	SUBADDRESS <sup>(4)</sup>	ACK <sup>(3)</sup>	DATA <sup>(5)</sup>	P <sup>(6)</sup>
------------------	------------------------------	--------------------	---------------------------	--------------------	---------------------	------------------

### Notes

- S = START condition.
- SLAVE ADDRESS = 1000 100X.
- ACK = acknowledge, generated by the slave.
- SUBADDRESS = subaddress byte, see Table 1.
- DATA = data byte, see Table 1.
- P = STOP condition.
- X = read/write control bit.  
X = 0, order to write (the circuit is slave receiver).  
X = 1, order to read (the circuit is slave transmitter).

If more than 1 byte of DATA is transmitted, then auto-increment of the subaddress is performed.

**Table 1** I<sup>2</sup>C-bus transmission; see Table 2

FUNCTION	SUBADDRESS	DATA							
		D7	D6	D5	D4	D3	D2	D1	D0
Y delay/SC	00010000	0	SC5	0	DL4	DL3	DL2	DL1	DL0
Peaking and coring	00010001	COR	PEAK	LCF	0	PCON3	PCON2	PCON1	PCON0

**Table 2** Function of the bits

DATA	FUNCTION	LOGIC 1	LOGIC 0
DL0	set delay in luminance channel	45 ns	0 ns
DL1		90 ns	0 ns
DL2		180 ns	0 ns
DL3		180 ns	0 ns
DL4		450 ns	0 ns
SC5	select sandcastle pulse voltage	+5 V	+12 V
LCF	set peaking frequency response	2.6 MHz	5.0 MHz
PEAK	set peaking delay	active (190 ns)	inactive
COR	set coring control	active	inactive
PCONx	set peaking amplification	see Table 3	

## Picture Signal Improvement (PSI) circuit with enhanced peaking function

TDA4672

**Table 3** Peaking amplification

PCON3	PCON2	PCON1	PCON0	GRADE OF PEAKING (dB)
1	1	1	1	-6
1	1	1	0	-5
1	1	0	1	-4
1	1	0	0	-3
1	0	1	1	-2
1	0	1	0	-1
1	0	0	1	0
1	0	0	0	+1
0	1	1	1	+2
0	1	1	0	+3
0	1	0	1	+4
0	1	0	0	+5
0	0	1	1	+6
0	0	1	0	+7
0	0	0	1	+8
0	0	0	0	+9

**Remarks to the subaddress bytes**

Subaddresses 00H to 0FH are reserved for colour decoders and RGB processors.

Subaddresses 10 and 11 only are acknowledged.

General call address is not acknowledged.

Power-on reset: D7 to D1 bits of data bytes are set to logic 0, D0 bit is set to logic 1.

# Picture Signal Improvement (PSI) circuit with enhanced peaking function

TDA4672

## INTERNAL CIRCUITRY

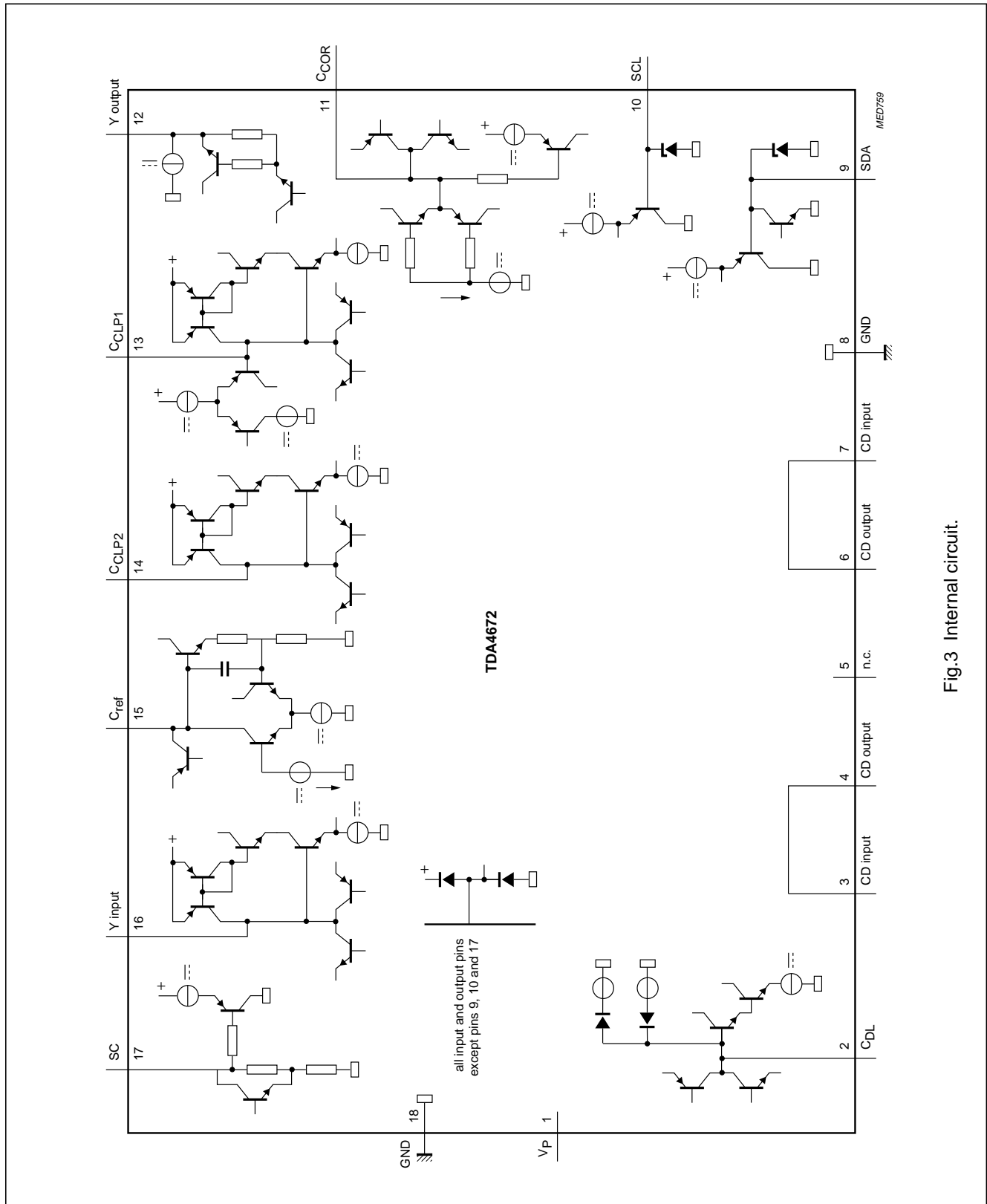

Fig.3 Internal circuit.

Picture Signal Improvement (PSI) circuit  
with enhanced peaking function

TDA4672

TEST AND APPLICATION INFORMATION

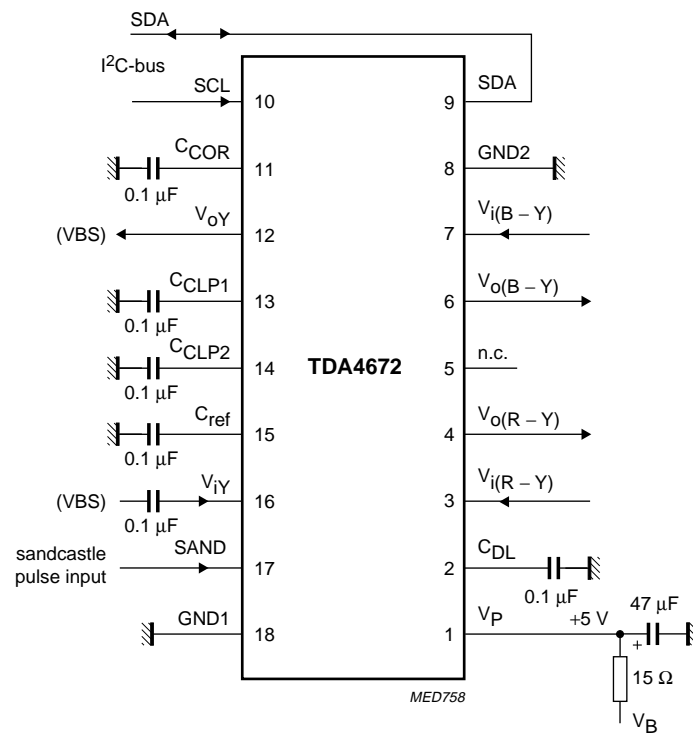

Fig.4 Test and application circuit.

Picture Signal Improvement (PSI) circuit  
with enhanced peaking function

TDA4672

PACKAGE OUTLINE

DIP18: plastic dual in-line package; 18 leads (300 mil)

SOT102-1

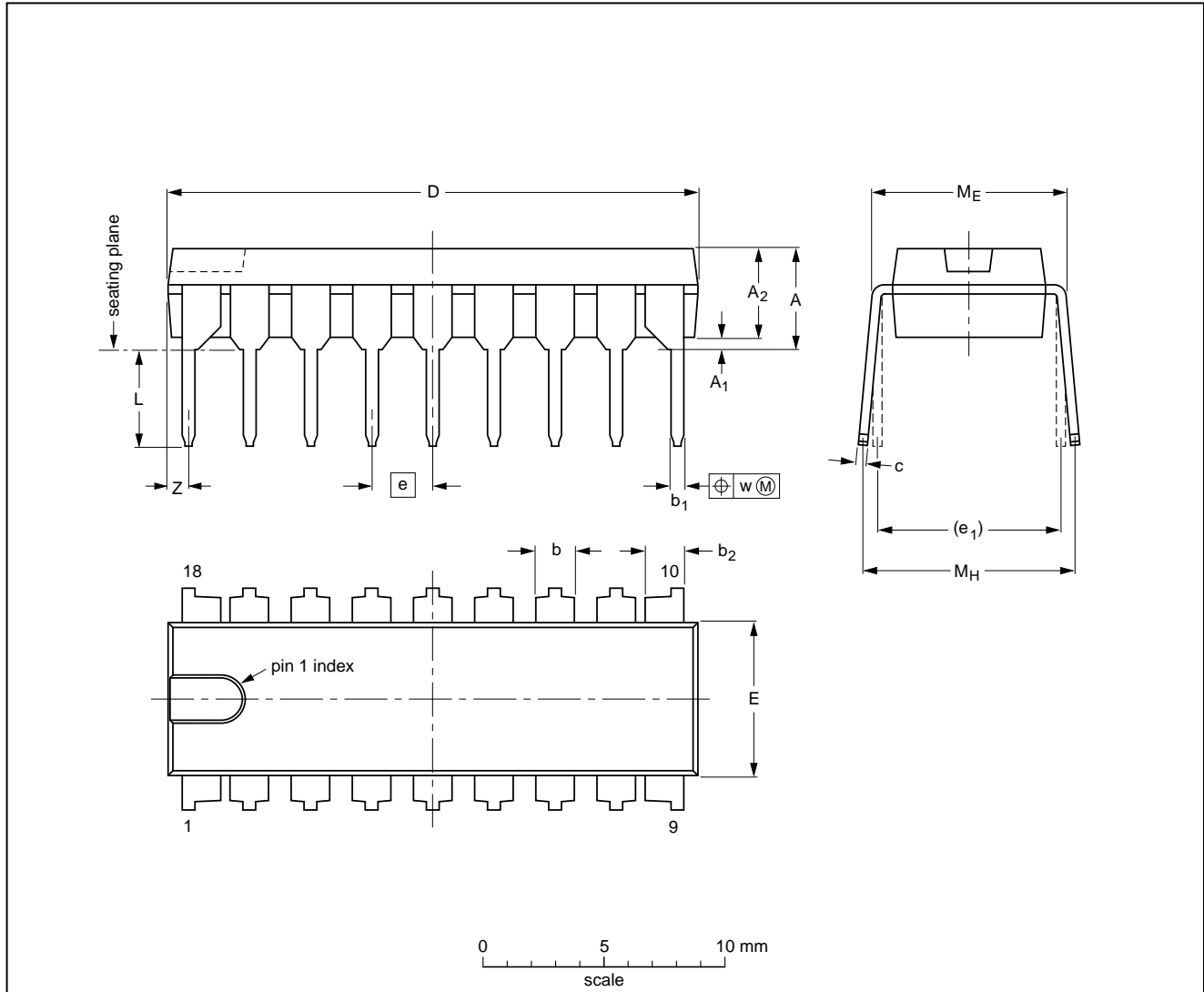

DIMENSIONS (inch dimensions are derived from the original mm dimensions)

UNIT	A max.	A <sub>1</sub> min.	A <sub>2</sub> max.	b	b <sub>1</sub>	b <sub>2</sub>	c	D <sup>(1)</sup>	E <sup>(1)</sup>	e	e <sub>1</sub>	L	M <sub>E</sub>	M <sub>H</sub>	w	Z <sup>(1)</sup> max.
mm	4.7	0.51	3.7	1.40 1.14	0.53 0.38	1.40 1.14	0.32 0.23	21.8 21.4	6.48 6.20	2.54	7.62	3.9 3.4	8.25 7.80	9.5 8.3	0.254	0.85
inches	0.19	0.020	0.15	0.055 0.044	0.021 0.015	0.055 0.044	0.013 0.009	0.86 0.84	0.26 0.24	0.10	0.30	0.15 0.13	0.32 0.31	0.37 0.33	0.01	0.033

Note

1. Plastic or metal protrusions of 0.25 mm maximum per side are not included.

OUTLINE VERSION	REFERENCES				EUROPEAN PROJECTION	ISSUE DATE
	IEC	JEDEC	EIAJ			
SOT102-1						93-10-14 95-01-23

## Picture Signal Improvement (PSI) circuit with enhanced peaking function

TDA4672

### SOLDERING

#### Introduction

There is no soldering method that is ideal for all IC packages. Wave soldering is often preferred when through-hole and surface mounted components are mixed on one printed-circuit board. However, wave soldering is not always suitable for surface mounted ICs, or for printed-circuits with high population densities. In these situations reflow soldering is often used.

This text gives a very brief insight to a complex technology. A more in-depth account of soldering ICs can be found in our "IC Package Databook" (order code 9398 652 90011).

#### Soldering by dipping or by wave

The maximum permissible temperature of the solder is 260 °C; solder at this temperature must not be in contact

with the joint for more than 5 seconds. The total contact time of successive solder waves must not exceed 5 seconds.

The device may be mounted up to the seating plane, but the temperature of the plastic body must not exceed the specified maximum storage temperature ( $T_{stg\ max}$ ). If the printed-circuit board has been pre-heated, forced cooling may be necessary immediately after soldering to keep the temperature within the permissible limit.

#### Repairing soldered joints

Apply a low voltage soldering iron (less than 24 V) to the lead(s) of the package, below the seating plane or not more than 2 mm above it. If the temperature of the soldering iron bit is less than 300 °C it may remain in contact for up to 10 seconds. If the bit temperature is between 300 and 400 °C, contact may be up to 5 seconds.

### DEFINITIONS

Data sheet status	
Objective specification	This data sheet contains target or goal specifications for product development.
Preliminary specification	This data sheet contains preliminary data; supplementary data may be published later.
Product specification	This data sheet contains final product specifications.
Limiting values	
Limiting values given are in accordance with the Absolute Maximum Rating System (IEC 134). Stress above one or more of the limiting values may cause permanent damage to the device. These are stress ratings only and operation of the device at these or at any other conditions above those given in the Characteristics sections of the specification is not implied. Exposure to limiting values for extended periods may affect device reliability.	
Application information	
Where application information is given, it is advisory and does not form part of the specification.	

### LIFE SUPPORT APPLICATIONS

These products are not designed for use in life support appliances, devices, or systems where malfunction of these products can reasonably be expected to result in personal injury. Philips customers using or selling these products for use in such applications do so at their own risk and agree to fully indemnify Philips for any damages resulting from such improper use or sale.

### PURCHASE OF PHILIPS I<sup>2</sup>C COMPONENTS



Purchase of Philips I<sup>2</sup>C components conveys a license under the Philips' I<sup>2</sup>C patent to use the components in the I<sup>2</sup>C system provided the system conforms to the I<sup>2</sup>C specification defined by Philips. This specification can be ordered using the code 9398 393 40011.

---

Picture Signal Improvement (PSI) circuit  
with enhanced peaking function

---

TDA4672

**NOTES**

# Philips Semiconductors – a worldwide company

**Argentina:** see South America

**Australia:** 34 Waterloo Road, NORTH RYDE, NSW 2113,  
Tel. +61 2 9805 4455, Fax. +61 2 9805 4466

**Austria:** Computerstr. 6, A-1101 WIEN, P.O. Box 213,  
Tel. +43 1 60 101, Fax. +43 1 60 101 1210

**Belarus:** Hotel Minsk Business Center, Bld. 3, r. 1211, Volodarski Str. 6,  
220050 MINSK, Tel. +375 172 200 733, Fax. +375 172 200 773

**Belgium:** see The Netherlands

**Brazil:** see South America

**Bulgaria:** Philips Bulgaria Ltd., Energoproject, 15th floor,  
51 James Bourchier Blvd., 1407 SOFIA,  
Tel. +359 2 689 211, Fax. +359 2 689 102

**Canada:** PHILIPS SEMICONDUCTORS/COMPONENTS,  
Tel. +1 800 234 7381

**China/Hong Kong:** 501 Hong Kong Industrial Technology Centre,  
72 Tat Chee Avenue, Kowloon Tong, HONG KONG,  
Tel. +852 2319 7888, Fax. +852 2319 7700

**Colombia:** see South America

**Czech Republic:** see Austria

**Denmark:** Prags Boulevard 80, PB 1919, DK-2300 COPENHAGEN S,  
Tel. +45 32 88 2636, Fax. +45 31 57 1949

**Finland:** Sinikalliontie 3, FIN-02630 ESPOO,  
Tel. +358 9 615800, Fax. +358 9 61580/xxx

**France:** 4 Rue du Port-aux-Vins, BP317, 92156 SURESNES Cedex,  
Tel. +33 1 40 99 6161, Fax. +33 1 40 99 6427

**Germany:** Hammerbrookstraße 69, D-20097 HAMBURG,  
Tel. +49 40 23 53 60, Fax. +49 40 23 536 300

**Greece:** No. 15, 25th March Street, GR 17778 TAVROS/ATHENS,  
Tel. +30 1 4894 339/239, Fax. +30 1 4814 240

**Hungary:** see Austria

**India:** Philips INDIA Ltd, Shivsagar Estate, A Block, Dr. Annie Besant Rd.  
Worli, MUMBAI 400 018, Tel. +91 22 4938 541, Fax. +91 22 4938 722

**Indonesia:** see Singapore

**Ireland:** Newstead, Clonskeagh, DUBLIN 14,  
Tel. +353 1 7640 000, Fax. +353 1 7640 200

**Israel:** RAPAC Electronics, 7 Kehilat Saloniki St, TEL AVIV 61180,  
Tel. +972 3 645 0444, Fax. +972 3 649 1007

**Italy:** PHILIPS SEMICONDUCTORS, Piazza IV Novembre 3,  
20124 MILANO, Tel. +39 2 6752 2531, Fax. +39 2 6752 2557

**Japan:** Philips Bldg 13-37, Kohnan 2-chome, Minato-ku, TOKYO 108,  
Tel. +81 3 3740 5130, Fax. +81 3 3740 5077

**Korea:** Philips House, 260-199 Itaewon-dong, Yongsan-ku, SEOUL,  
Tel. +82 2 709 1412, Fax. +82 2 709 1415

**Malaysia:** No. 76 Jalan Universiti, 46200 PETALING JAYA, SELANGOR,  
Tel. +60 3 750 5214, Fax. +60 3 757 4880

**Mexico:** 5900 Gateway East, Suite 200, EL PASO, TEXAS 79905,  
Tel. +9-5 800 234 7381

**Middle East:** see Italy

**Netherlands:** Postbus 90050, 5600 PB EINDHOVEN, Bldg. VB,  
Tel. +31 40 27 82785, Fax. +31 40 27 88399

**New Zealand:** 2 Wagener Place, C.P.O. Box 1041, AUCKLAND,  
Tel. +64 9 849 4160, Fax. +64 9 849 7811

**Norway:** Box 1, Manglerud 0612, OSLO,  
Tel. +47 22 74 8000, Fax. +47 22 74 8341

**Philippines:** Philips Semiconductors Philippines Inc.,  
106 Valero St. Salcedo Village, P.O. Box 2108 MCC, MAKATI,  
Metro MANILA, Tel. +63 2 816 6380, Fax. +63 2 817 3474

**Poland:** Ul. Lukiska 10, PL 04-123 WARSZAWA,  
Tel. +48 22 612 2831, Fax. +48 22 612 2327

**Portugal:** see Spain

**Romania:** see Italy

**Russia:** Philips Russia, Ul. Usatcheva 35A, 119048 MOSCOW,  
Tel. +7 095 247 9145, Fax. +7 095 247 9144

**Singapore:** Lorong 1, Toa Payoh, SINGAPORE 1231,  
Tel. +65 350 2538, Fax. +65 251 6500

**Slovakia:** see Austria

**Slovenia:** see Italy

**South Africa:** S.A. PHILIPS Pty Ltd., 195-215 Main Road Martindale,  
2092 JOHANNESBURG, P.O. Box 7430 Johannesburg 2000,  
Tel. +27 11 470 5911, Fax. +27 11 470 5494

**South America:** Rua do Rocio 220, 5th floor, Suite 51,  
04552-903 São Paulo, SÃO PAULO - SP, Brazil,  
Tel. +55 11 821 2333, Fax. +55 11 829 1849

**Spain:** Balmes 22, 08007 BARCELONA,  
Tel. +34 3 301 6312, Fax. +34 3 301 4107

**Sweden:** Kottbygatan 7, Akalla, S-16485 STOCKHOLM,  
Tel. +46 8 632 2000, Fax. +46 8 632 2745

**Switzerland:** Allmendstrasse 140, CH-8027 ZÜRICH,  
Tel. +41 1 488 2686, Fax. +41 1 481 7730

**Taiwan:** PHILIPS TAIWAN Ltd., 23-30F, 66,  
Chung Hsiao West Road, Sec. 1, P.O. Box 22978,  
TAIPEI 100, Tel. +886 2 382 4443, Fax. +886 2 382 4444

**Thailand:** PHILIPS ELECTRONICS (THAILAND) Ltd.,  
209/2 Sanpavuth-Bangna Road Prakanong, BANGKOK 10260,  
Tel. +66 2 745 4090, Fax. +66 2 398 0793

**Turkey:** Talatpasa Cad. No. 5, 80640 GÜLTEPE/ISTANBUL,  
Tel. +90 212 279 2770, Fax. +90 212 282 6707

**Ukraine:** PHILIPS UKRAINE, 4 Patrice Lumumba str., Building B, Floor 7,  
252042 KIEV, Tel. +380 44 264 2776, Fax. +380 44 268 0461

**United Kingdom:** Philips Semiconductors Ltd., 276 Bath Road, Hayes,  
MIDDLESEX UB3 5BX, Tel. +44 181 730 5000, Fax. +44 181 754 8421

**United States:** 811 East Arques Avenue, SUNNYVALE, CA 94088-3409,  
Tel. +1 800 234 7381

**Uruguay:** see South America

**Vietnam:** see Singapore

**Yugoslavia:** PHILIPS, Trg N. Pasica 5/v, 11000 BEOGRAD,  
Tel. +381 11 625 344, Fax. +381 11 635 777

**For all other countries apply to:** Philips Semiconductors, Marketing & Sales Communications,  
Building BE-p, P.O. Box 218, 5600 MD EINDHOVEN, The Netherlands, Fax. +31 40 27 24825

**Internet:** <http://www.semiconductors.philips.com>

© Philips Electronics N.V. 1996

SCA52

All rights are reserved. Reproduction in whole or in part is prohibited without the prior written consent of the copyright owner.

The information presented in this document does not form part of any quotation or contract, is believed to be accurate and reliable and may be changed without notice. No liability will be accepted by the publisher for any consequence of its use. Publication thereof does not convey nor imply any license under patent- or other industrial or intellectual property rights.

Printed in The Netherlands

537021/1200/03/pp16

Date of release: 1996 Dec 11

Document order number: 9397 750 01473

*Let's make things better.*

**Philips**  
Semiconductors



**PHILIPS**