

# DATA SHEET

## **TDA3858**

Quasi-split sound processor for all standards

Product specification  
File under Integrated Circuits, IC02

June 1994

# Quasi-split sound processor for all standards

# TDA3858

## FEATURES

- Quasi-split sound processor for all standards e. g. B/G (FM sound) and L (AM sound)
- Reducing of spurious video signals by tracking function and AFC for the vision carrier reference circuit; (recommended for NICAM)
- Automatic muting of the AF2 signal (at B/G) by the input level
- AM signal processing for L standard and switching over the audio signal
- Stereo matrix correction
- Layout-compatible with TDA3856 (24 pins) and TDA3857 (20 pins).

## GENERAL DESCRIPTION

Separate symmetrical IF inputs for FM or AM sound.

Gain controlled wideband IF amplifier, input select switch. AGC generation due to peak sync for FM or mean signal level for AM. Reference amplifier for the regeneration of the vision carrier. Optimized limiting amplifier for AM suppression in the regenerated vision carrier signal and 90° phase shifter.

Intercarrier mixer for FM sound, output with low-pass filter. Separate signal processing for 5.5 and 5.74 MHz intercarriers. Wide supply voltage range, only 300 mW power dissipation at 5 V.

## QUICK REFERENCE DATA

SYMBOL	PARAMETER	MIN.	TYP.	MAX.	UNIT
V <sub>P1</sub>	supply voltage (pin 27)	4.5	5	8.8	V
V <sub>P2</sub>	alternative supply voltage (pin 28)	10.8	12	13.2	V
<b>Data at V<sub>P1</sub> = 5 V</b>					
I <sub>P</sub>	supply current (pin 27)	–	60	72	mA
V <sub>i IF</sub>	IF input sensitivity (–3 dB)	–	70	100	μV
V <sub>O (RMS)</sub>	audio output signal for FM (B/G)	–	1	–	V
V <sub>O (RMS)</sub>	audio output signal for AM (L)	–	0.6	–	V
THD	total harmonic distortion				
	for FM	–	0.5	–	%
	for AM	–	1	–	%
S/N (W)	weighted signal-to-noise ratio				
	for FM	–	68	–	dB
	for AM	–	56	–	dB

## ORDERING INFORMATION

EXTENDED TYPE NUMBER	PACKAGE			
	PINS	PIN POSITION	MATERIAL	CODE
TDA3858	32	shrink DIL	plastic	SOT232 <sup>(1)</sup>

### Note

1. SOT 232-1; 1996 November 21.

Quasi-split sound processor for all standards

TDA3858

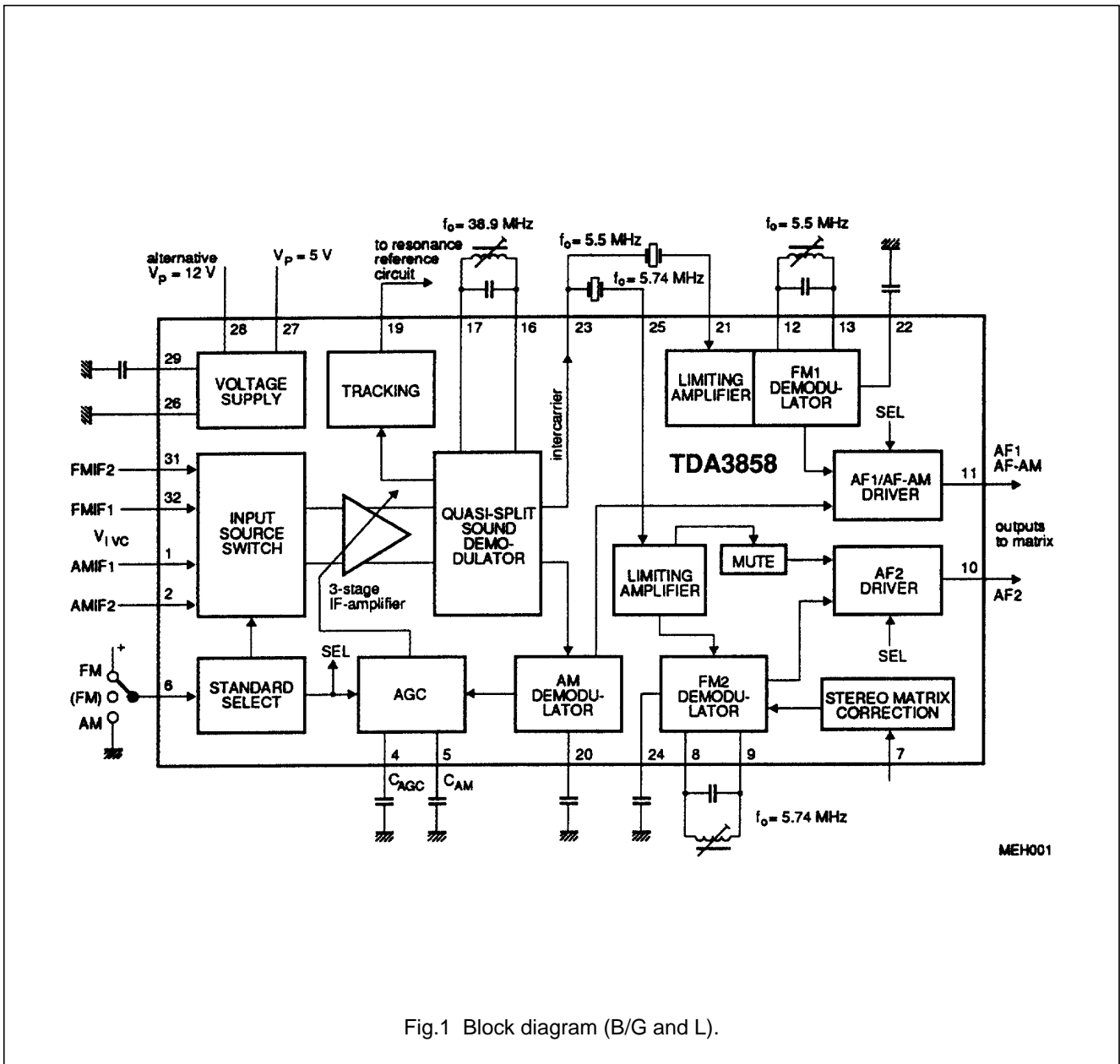

Fig.1 Block diagram (B/G and L).

Quasi-split sound processor for all standards

TDA3858

**PINNING**

SYMBOL	PIN	DESCRIPTION
AMIF1	1	AM IF difference input 1 for L standard (32.4 MHz)
AMIF2	2	AM IF difference input 2 for L standard (32.4 MHz)
n.c.	3	not connected
C <sub>AGC</sub>	4	charge capacitor for AGC (FM and AM)
C <sub>AM</sub>	5	charge capacitor for AM AGC
MODE	6	3-state input for standard select
MATR	7	input for stereo matrix correction
FM2R1	8	reference circuit for FM2 (5.74 MHz)
FM2R2	9	reference circuit for FM2 (5.74 MHz)
AF2	10	AF2 output (AF out of 5.74 MHz)
AF1	11	AF1 output (AF out of 5.5 MHz or AM)
FM1R1	12	reference circuit for FM1 (5.5 MHz)
FM1R2	13	reference circuit for FM1 (5.5 MHz)
n.c.	14	not connected
n.c.	15	not connected
VC-R1	16	reference circuit for the vision carrier (38.9 MHz)
VC-R2	17	reference circuit for the vision carrier (38.9 MHz)
n.c.	18	not connected
TRACK	19	DC output level for tracking
C <sub>AFAM</sub>	20	DC decoupling capacitor for AM demodulator (AF-AM)
FM1I	21	intercarrier input for FM1 (5.5. MHz)
C <sub>AF1</sub>	22	DC decoupling capacitor for FM1 demodulator (AF1)
ICO	23	intercarrier output signal (5.5/5.74 MHz)
C <sub>AF2</sub>	24	DC decoupling capacitor for FM2 demodulator (AF2)
FM2I	25	intercarrier input for FM2 (5.74 MHz)
GND	26	ground (0 V)
V <sub>P1</sub>	27	+5 to +8 V supply voltage (pin 28 not connected)
V <sub>P2</sub>	28	+ 12 V supply voltage (pin 27 not connected)
C <sub>REF</sub>	29	charge capacitor for reference voltage
n.c.	30	not connected
FMIF1	31	IF difference input 1 for B/G standard (38.9 MHz)
FMIF2	32	IF difference input 2 for B/G standard (38.9 MHz)

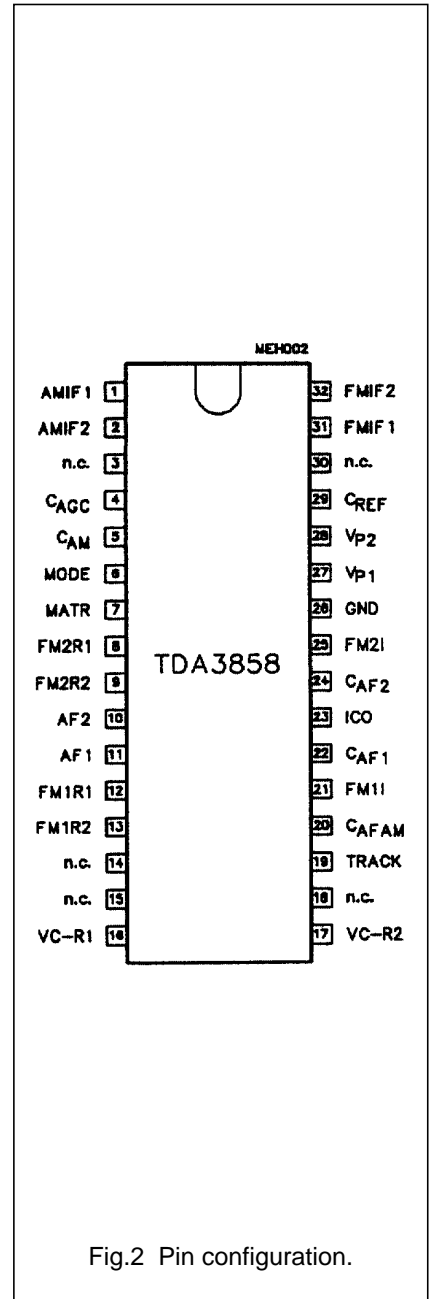

Fig.2 Pin configuration.

## Quasi-split sound processor for all standards

TDA3858

### FUNCTIONAL DESCRIPTION

The quasi-split sound processor is suitable for all standards. Dependent on the voltage at pin 6 either FM mode (B/G) or AM mode (L) is selected.

#### B/G standard (FM mode)

Pins 31 and 32 are active, AGC detector uses peak sync level. Sound carrier SC1 (5.5 MHz) provides AF1, sound carrier SC2 (5.74 MHz) provides AF2.

#### Muting

With no sound carrier SC2 at pin 25, AF2 output is muted (in mid-position of the standard select switch FM mode without muting of AF2 is selected).

The mute circuit prevents false signal recognition in the stereo decoder at high IF signal levels when no second sound carrier exists (mono) and an AF signal is present in the identification signal frequency range. With 1 mV at pin 25, under measurement conditions, AF2 is switched on (see limiting amplifier). Weak input signals at pins 31 and 32 generate noise at pin 25, which is present in the intercarrier signal and passes through the 5.74 MHz filter. Noise at pin 25 inhibits muting. No misinterpretation due to white noise occurs in the stereo decoder, when non-correlated noise masks the identification signal frequencies, which may be present in sustained tone signals. The stereo decoder remains switched to mono.

#### L standard (AM mode)

Pins 1 and 2 are active, AGC detector uses mean signal level. The audio signal from the AM demodulator is output on AF1, with AF2 output muted.

#### Sound carrier notch filter for an improved intercarrier buzz

The series capacitor  $C_S$  in the 38.9 MHz resonant circuit provides a notch at the sound carrier frequency in order to provide more attenuation for the sound carrier in the vision carrier reference channel. The ratio of parallel/series capacitor depends on the ratio of VC/SC frequency and has to be adapted to other TV transmission standards if necessary, according to the formula

$$C_S = C_P (f_{VC}/f_{SC})^2 - C_P.$$

The result is an improved intercarrier buzz (up to 10 dB improvement in sound channel 2 with 250 kHz video modulation for B/G stereo) or suppression of 350 kHz video modulated beat frequency in the digitally-modulated NICAM subcarrier.

#### Intercarrier buzz fine tuning with 250 kHz square wave video modulation

The picture carrier for quadrature demodulation in the intercarrier mixer is not exactly 90 degrees due to the shift variation in the integrated phase shift network. The tuning of the LC reference circuit to provide optimal video suppression at the intercarrier output is not the same as that to provide optimal intercarrier buzz suppression. In order to optimize the AF signal performance, a fine tuning for the optimal S/N at the sound channel 2 (from 5.74 MHz) may be performed with a 250 kHz square wave video modulation.

#### Measurements at the demodulators

For all signal-to-noise measurements the generator must meet the following specifications:

phase modulation errors  $< 0.5^\circ$  for B/W-jumps

intercarrier signal-to-noise ratio as measured with 'TV-demodulator AMF2' (weighted S/N) must be  $> 60$  dB at 6 kHz sine wave modulation of the B/W-signal.

Signal-to-noise ratios are measured with  $\Delta f = \pm 50$  kHz deviation and  $f_{mod} = 1$  kHz; with a deviation of  $\pm 30$  kHz the S/N ratio is deteriorated by 4.5 dB.

## Quasi-split sound processor for all standards

TDA3858

**LIMITING VALUES**

In accordance with the Absolute Maximum Rating System (IEC 134).

SYMBOL	PARAMETER	MIN.	MAX.	UNIT
V <sub>P1</sub>	supply voltage (pin 27)	–	8.8	V
V <sub>P2</sub>	supply voltage (pin 28)	–	13.2	V
V <sub>I</sub>	voltage (pins 1, 2, 6, 10, 11, 21, 23, 25, 31 and 32)	0	V <sub>P</sub>	V
V <sub>I(12 V)</sub>	voltage at 12 V supply (pin 6)	0	5.5	V
P <sub>tot</sub>	total power dissipation	0	950	mW
T <sub>stg</sub>	storage temperature	–25	+150	°C
T <sub>amb</sub>	operating ambient temperature	0	+70	°C
V <sub>ESD</sub>	electrostatic handling (note 1)			
	all pins except pins 1, 2, 31 and 32	±500	–	V
	pins 1, 2, 31 and 32	+400	–	V
		–500	–	V

**Note to the Limiting Values**

1. Equivalent to discharging a 200 pF capacitor through a 0 Ω series resistor.

## Quasi-split sound processor for all standards

## TDA3858

**CHARACTERISTICS**

$V_P = 5\text{ V}$  (pin 27) and  $T_{\text{amb}} = +25\text{ }^\circ\text{C}$ ; measurements taken in Fig.3 with  $f_{\text{VC}} = 38.9\text{ MHz}$ ,  $f_{\text{SC1}} = 33.4\text{ MHz}$  and  $f_{\text{SC2}} = 33.158\text{ MHz}$ . Vision carrier (VC) modulated with different video signals, modulation depth 100% (proportional to 10% residual carrier).

Vision carrier amplitude (RMS value)  $V_{i\text{VC}} = 10\text{ mV}$ ; vision to sound carrier ratios are  $\text{VC/SC1} = 13\text{ dB}$  and  $\text{VC/SC2} = 20\text{ dB}$ . Sound carriers (SC1, SC2) modulated with  $f = 1\text{ kHz}$  and deviation  $\Delta f = 50\text{ kHz}$ , unless otherwise specified.

SYMBOL	PARAMETER	CONDITIONS	MIN.	TYP.	MAX.	UNIT
$V_{P1}$	supply voltage (pin 27)	pin 28 not connected	4.5	5	8.8	V
$V_{P2}$	supply voltage (pin 28)	pin 27 not connected	10.8	12	13.2	V
$I_{P1}$	supply current (pin 27)	$V_{P1} = 5\text{ V}$	48	60	72	mA
<b>IF source control</b> (pin 6)						
$V_6$	input voltage in order to obtain standards					
	B/G (FM) with automatic muting	pin 6 connected pin 6 open-circuit	2.8 –	– 2.8	$V_{P1}$ –	V V
	B/G (FM) without muting	pin 6 connected or alternative measure: 22 k $\Omega$ to GND	1.3	–	2.3	V
	L(AM sound)	pin 6 connected	0	–	0.8	V
$I_6$	input current	$V_6 = V_{P1}$	–	–	100	$\mu\text{A}$
		$V_6 = 0\text{ V}$	–	–	–300	$\mu\text{A}$
$V_{6(12\text{ V})}$	maximum input voltage (pin 6)	supply at pin 28	–	–	5.5	V
<b>IF input not activated</b> (pins 1-2 or 31-32)						
$R_I$	input resistance		–	–	100	$\Omega$
$V_I$	DC input voltage (pins 1, 2 or 31, 32)	LOW set internally	–	–	0.1	V
$\alpha_{16-17}$	crosstalk attenuation of IF input switch	note 1	50	56	–	dB
<b>IF amplifier</b> (pins 1-2 or 31-32)						
$R_I$	input resistance		1.8	2.2	–	k $\Omega$
$C_I$	input capacitance		–	2.0	2.6	pF
$V_I$	DC potential, voltage (pins 1, 2, 31, 32)		–	1.75	–	V
$V_{i\text{IF (RMS)}}$	maximum input signal (RMS value)	$V_o = +1\text{ dB}$	70	100	–	mV
	input signal sensitivity B/G standard (RMS value, pins 31-32)	–3 dB intercarrier signal reduction at pin 23	–	70	100	$\mu\text{V}$
	input signal sensitivity L standard (RMS value, pin 1-2)	–3 dB intercarrier signal reduction at pin 11	–	70	100	$\mu\text{V}$

## Quasi-split sound processor for all standards

## TDA3858

SYMBOL	PARAMETER	CONDITIONS	MIN.	TYP.	MAX.	UNIT
$V_4$	voltage for gain control (pin 4)		1.7	–	2.6	V
$\Delta G_V$	IF gain control		60	63	–	dB
B	IF bandwidth	–3 dB	50	70	–	MHz
<b>Resonance amplifier</b> (pins 16-17)						
$V_{o(p-p)}$	vision carrier amplitude (peak-to-peak value)	$f_o = 38.9$ MHz	–	270	–	mV
$R_{16-17}$	operating resistance		–	4	–	k $\Omega$
L	inductance	Figs 3 and 5	–	0.247	–	$\mu$ H
C	capacitance		–	68	–	pF
$Q_L$	Q-factor of resonant circuit	$Q_o = 90$	–	40	–	
$V_{16, 17}$	DC voltage (pins 16 and 17)		–	$V_{P1} - 1$	–	V
<b>Intercarrier mixer output</b> (pin 23)						
$V_{o(RMS)}$	output signal for 5.5 MHz (RMS value)		71	95	125	mV
	output signal for 5.74 MHz (RMS value)		32	43	56	mV
B	IF bandwidth	–1 dB	6	8.5	–	MHz
		–3 dB	7	10	–	MHz
$V_{VID}/V_{23}$	residual video AM on intercarrier	note 2	–	3	10	%
$V_{VC(RMS)}$	residual vision carrier (RMS value)	1st/2nd harmonic (38.9/77.8 MHz)	–	0.5	1	mV
$R_{23}$	output resistance (emitter follower)	1 mA emitter current	–	30	–	$\Omega$
$I_o$	allowable AC output current (pin 23)		–	–	$\pm 0.7$	mA
$I_{23}$	allowable DC output current		–	–	–2	mA
$V_{23}$	DC voltage	LC-circuit at pin 16, 17 adjusted to minimum video content at pin 23	1.5	1.75	2.0	V
<b>Limiting amplifiers</b> (pins 21 and 25)						
$V_{i(RMS)}$	minimum input signal (RMS value)	–3 dB AF signal	–	300	450	$\mu$ V
	maximum input signal (RMS value)		200	–	–	mV
$R_{21, 25}$	input resistance		450	560	700	$\Omega$
$V_{21, 25}$	DC voltage		–	0	–	V
$V_{i(RMS)}$	level detector threshold for no muting (RMS value, pin 25)	only 5.74 MHz channel	0.8	1.2	1.7	mV
$\Delta V_i$	hysteresis of level detector		4	7	12	dB



## Quasi-split sound processor for all standards

## TDA3858

SYMBOL	PARAMETER	CONDITIONS	MIN.	TYP.	MAX.	UNIT
<b>Tracking</b> Automatic Frequency Control (AFC) of the vision carrier reference circuit						
$V_{019}$	tracking output voltage (pin 19)	note 3	$V_{P1} - 3.3$	–	$V_{P1} - 1$	V
$F_{TR}$	tracking reducing factor for black picture		–	9	–	
	white test picture		–	4	–	
	50% grey picture		–	6	–	
S	AFC steepness (open loop) for black picture		–	–8	–	mV/kHz
	white test picture		–	–3	–	mV/kHz
	50% grey picture		–	–5.5	–	mV/kHz
<b>FM1 and FM2 demodulators</b>						
Measurements with FM IF input signals of 5.5 MHz and 5.74 MHz with $V_{iIF(RMS)} = 10$ mV ( $f_{mod} = 1$ kHz, deviation $\Delta f = \pm 50$ kHz) at pins 21 and 25 without ceramic filters, $R_S = 50 \Omega$ . De-emphasis 50 $\mu$ s and $V_6 = V_{P1}$ (B/G standard). $Q_L$ -factor = 11 for resonant circuits at pins 8-9 and 12-13 (including IC).						
$V_{IC(RMS)}$	intercarrier signals (RMS values, pins 8-9 and 12-13)		–	100	–	mV
V	DC voltage (pins 8, 9, 12 and 13)		–	1.8	–	V
$V_{o(RMS)}$	AF output signals (RMS values, pins 10 and 11)		0.84	0.95	1.07	V
$\Delta V_o$	difference of AF signals between channels (pins 10 and 11)	note 4	–	–	1	dB
$R_{10,11}$	output resistance		75	100	130	$\Omega$
$V_{10,11}$	DC voltage		1.8	2.1	2.4	V
$I_{10,11(M)}$	allowed AC current of emitter output (peak value)	note 5	–	–	$\pm 1.5$	mA
$I_{10,11}$	maximum allowed DC output current		–	–	–2	mA
THD	total harmonic distortion		–	0.5	1.0	%
$V_{o(RMS)}$	AF output signal (RMS value)	THD = 1.5%	1.25	–	–	V
$\alpha_{AM}$	AM suppression	1 kHz; $m = 0.3$	48	54	–	dB
S/N(W)	weighted signal-to-noise ratio	CCIR468-3	64	68	–	dB
B	AF bandwidth (–3 dB) lower limit		–	–	20	Hz
	upper limit		100	–	–	kHz
$\alpha_{CR}$	crosstalk attenuation (pins 10-11)		60	70	–	dB
$V_7$	adjustment voltage for AF2	note 6	–	0	–	V
		minimum output signal maximum output signal	–	5	–	V



## Quasi-split sound processor for all standards

TDA3858

SYMBOL	PARAMETER	CONDITIONS	MIN.	TYP.	MAX.	UNIT
<b>AF performance for FM operation (standard B/G)</b>						
input signals: B/G IF input signal (pin 31, 32) unmodulated sound carriers different video modulation (100%) the output signals are related to the signals described in the demodulator parts.						
(S+N)/N(W)	weighted signal-to-noise ratio	CCIR468-3; de-emphasis 50 $\mu$ s				
	black picture	$f_i = 5.5$ MHz	59	63	–	dB
	2T/20T pulses with white bar	$f_i = 5.5$ MHz	57	61	–	dB
	6 kHz sine wave, B/W-modulated	$f_i = 5.5$ MHz	52	56	–	dB
	250 kHz square wave, B/W-modulated	$f_i = 5.5$ MHz	50	54	–	dB
	black picture	$f_i = 5.742$ MHz	57	61	–	dB
	2T/20T pulses with white bar	$f_i = 5.742$ MHz	55	59	–	dB
	6 kHz sine wave, B/W-modulated	$f_i = 5.742$ MHz	50	54	–	dB
	250 kHz square wave, B/W-modulated	$f_i = 5.742$ MHz	48	52	–	dB
<b>Ripple rejection of the AF outputs (B/G and L standard)</b>						
RR	ripple rejection $V_{\text{ripple on } V_P} / V_{\text{ripple on } V_{\text{out}}}$	$V_{R(p-p)} = 200$ mV; $f_R = 70$ Hz	30	40	–	dB

**Notes to the characteristics**

- Crosstalk attenuation of IF input switch, measured at  $R_{16-17} = 470 \Omega$  (instead of LC circuit); input signal  $V_{i(RMS)} = 20$  mV (pins 31-32). AGC voltage  $V_4$  set to a value to achieve  $V_{o(RMS)} = 20$  mV (pins 16-17). After switching ( $V_6 = 0$  V) measure attenuation.  
IF coupling with OFWG3203 and OFWL9350 (Siemens).
- Spurious intercarrier AM:  $m = (A - B)/A$  (A = signal at sync; B = signal with 100% picture modulation).
- Automatic Frequency Control (AFC) of the vision carrier reference circuit (pins 16 and 17) for reducing spurious video signals in the stereo/dual sound modes. The factor of reducing  $F_{TR}$  at a deviation  $\Delta f_{VC}$  specifies the ratio of spurious signals with/without tracking function.
- AF signal can be adjusted by  $V_7$ .
- For larger current:  $R_L > 2.2$  k $\Omega$  (pin 10 or 11 to GND) in order to increase the bias current of the output emitter follower.
- If not used, pin 7 should not be connected.

Quasi-split sound processor for all standards

TDA3858

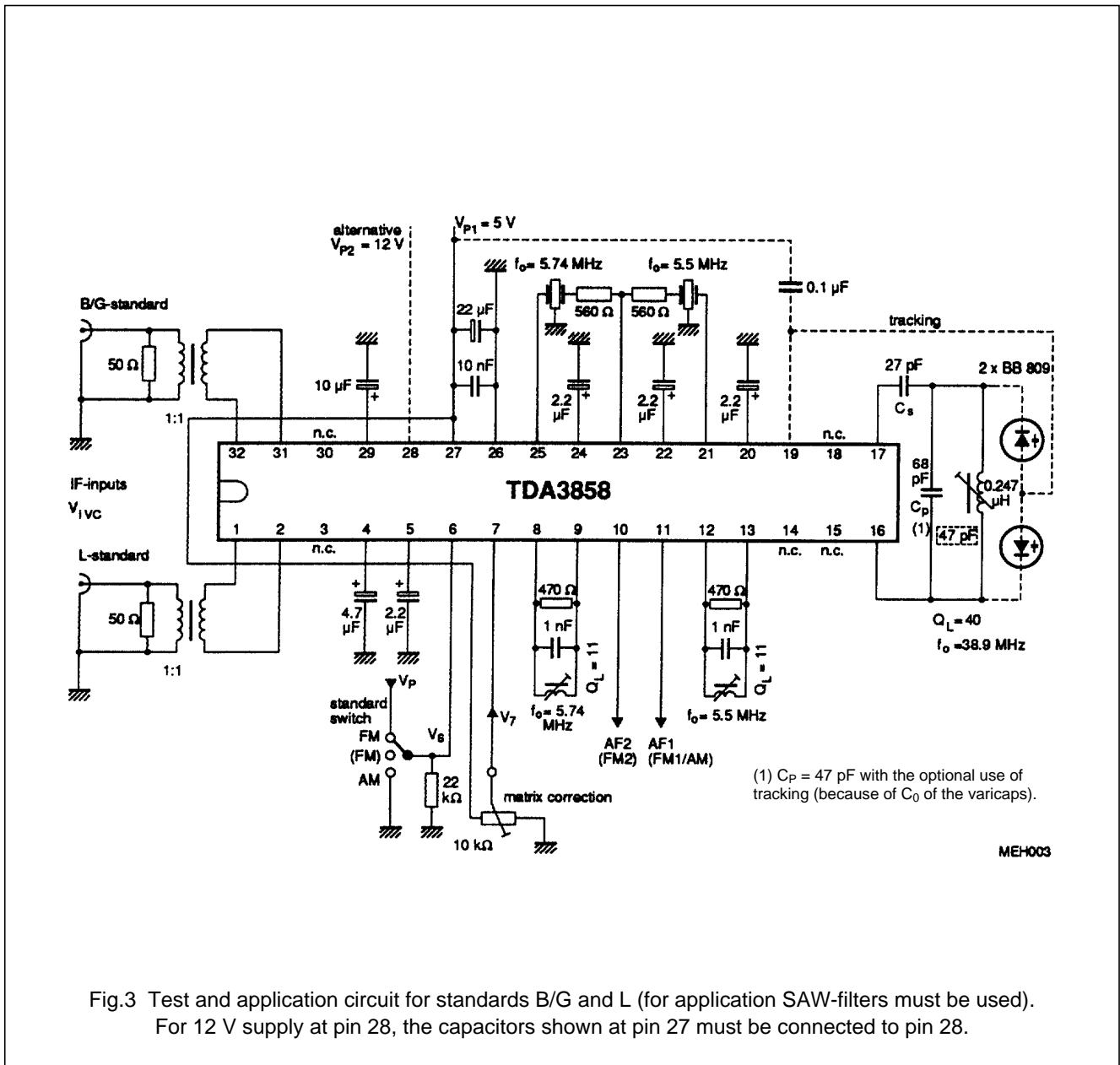

Fig.3 Test and application circuit for standards B/G and L (for application SAW-filters must be used).  
For 12 V supply at pin 28, the capacitors shown at pin 27 must be connected to pin 28.

Quasi-split sound processor for all standards

TDA3858

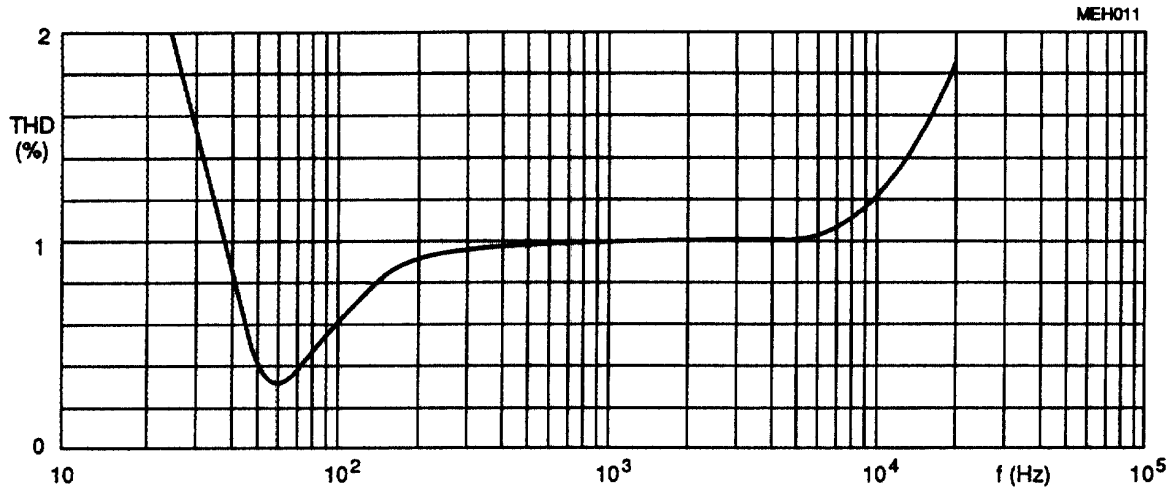
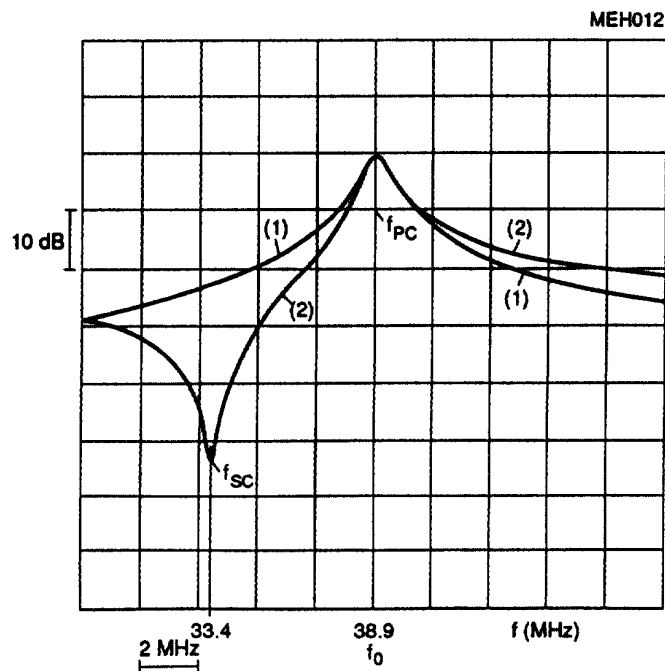

Fig.4 Total harmonic distortion (THD) as a function of audio frequency at AM standard ( $V_6 = 0$ ).



- (1) simple resonant circuit
- (2) resonant circuit with  $C_P = 68$  pF

$C_S = C_P (f_{VC}/f_{SC})^2 - C_P$   
 $C_S = 27$  pF (see Fig.3)

Fig.5 Frequency response of the 38.9 MHz reference circuit.

Quasi-split sound processor for all standards

TDA3858

APPLICATION INFORMATION

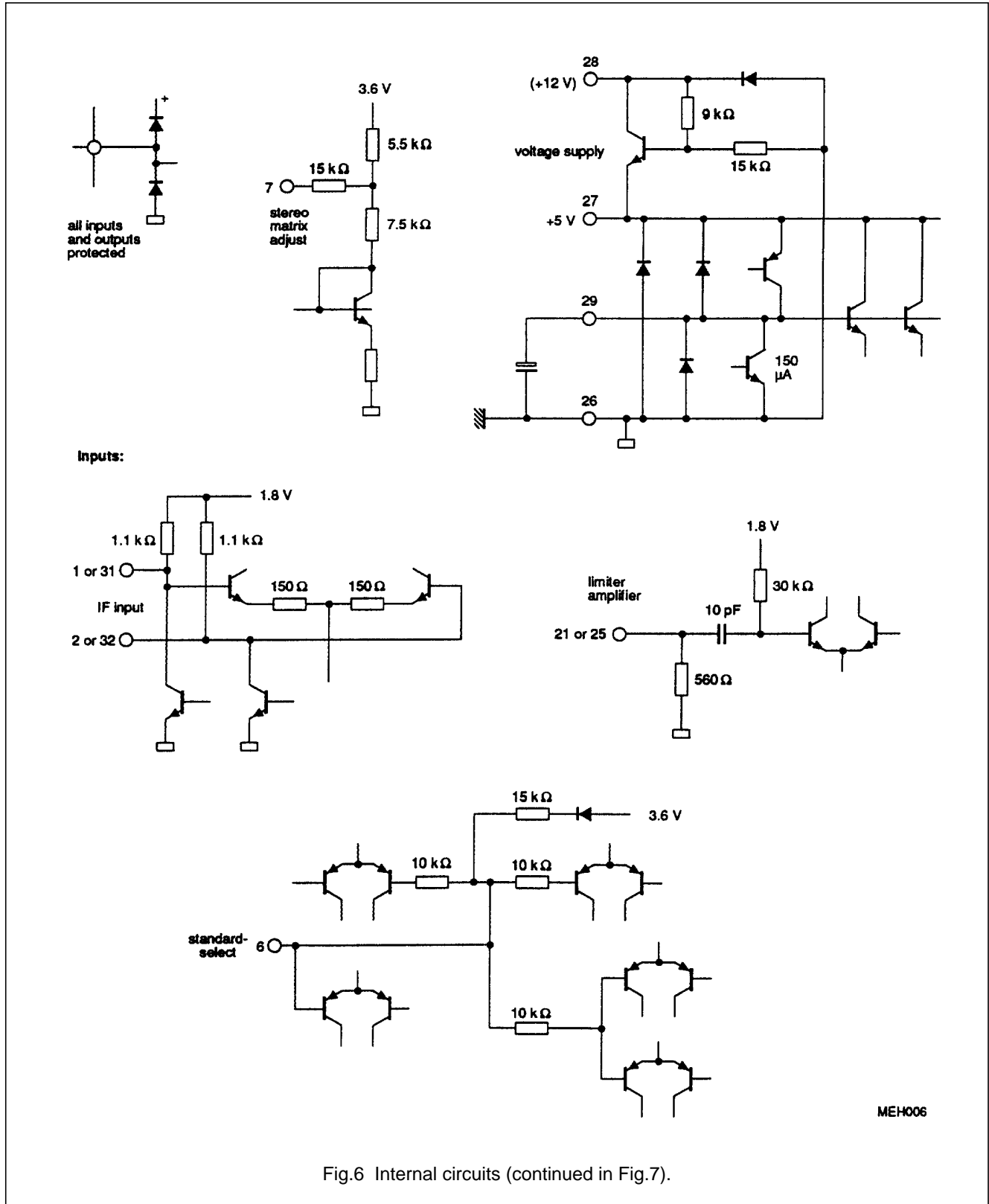

MEH006

Fig.6 Internal circuits (continued in Fig.7).

Quasi-split sound processor for all standards

TDA3858

Reference circuits:

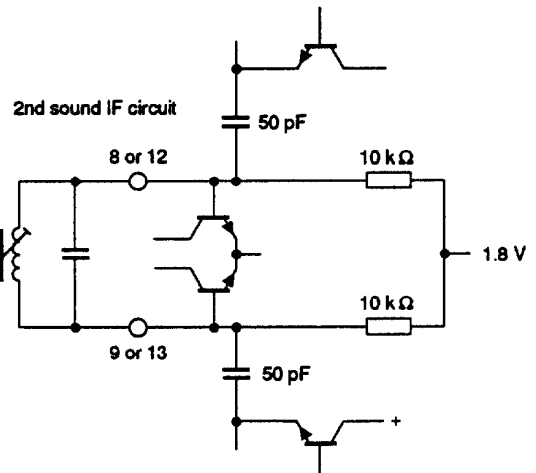
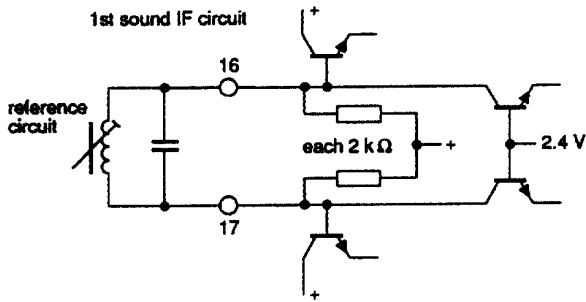

Driver outputs and decouplings:

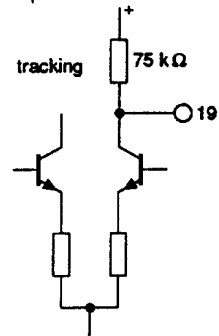
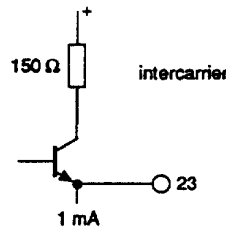
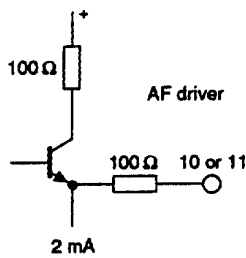

Capacitor pins:

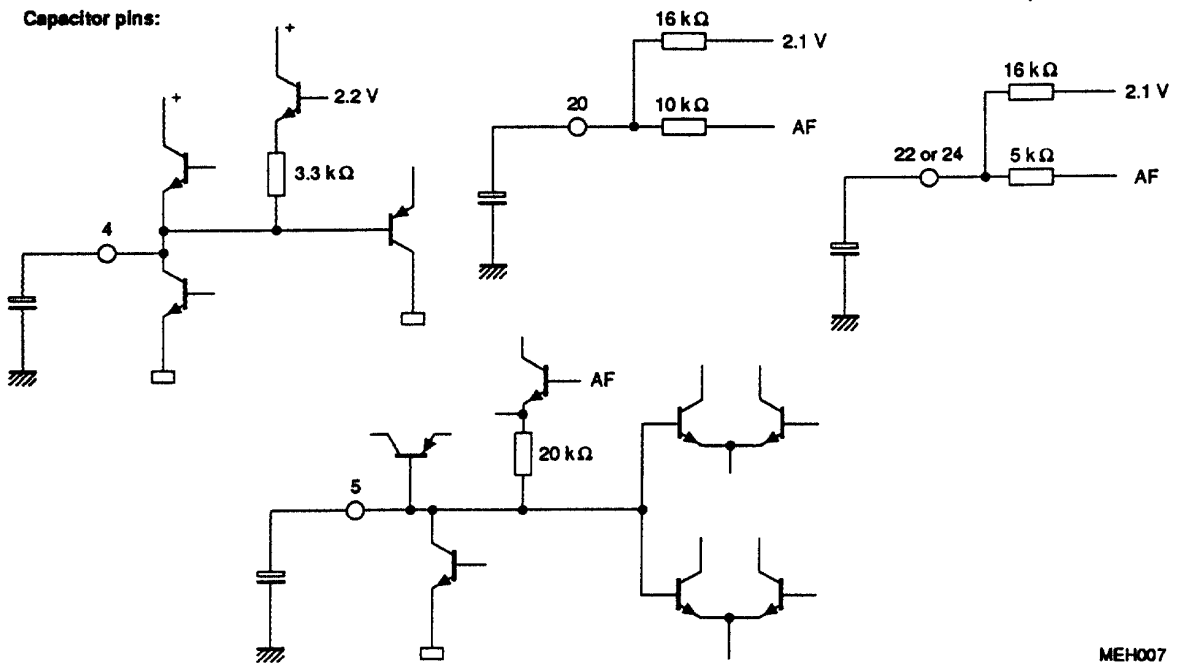

MEH007

Fig.7 Internal circuits (continued from Fig.6).

Quasi-split sound processor for all standards

TDA3858

PACKAGE OUTLINE

SDIP32: plastic shrink dual in-line package; 32 leads (400 mil)

SOT232-1

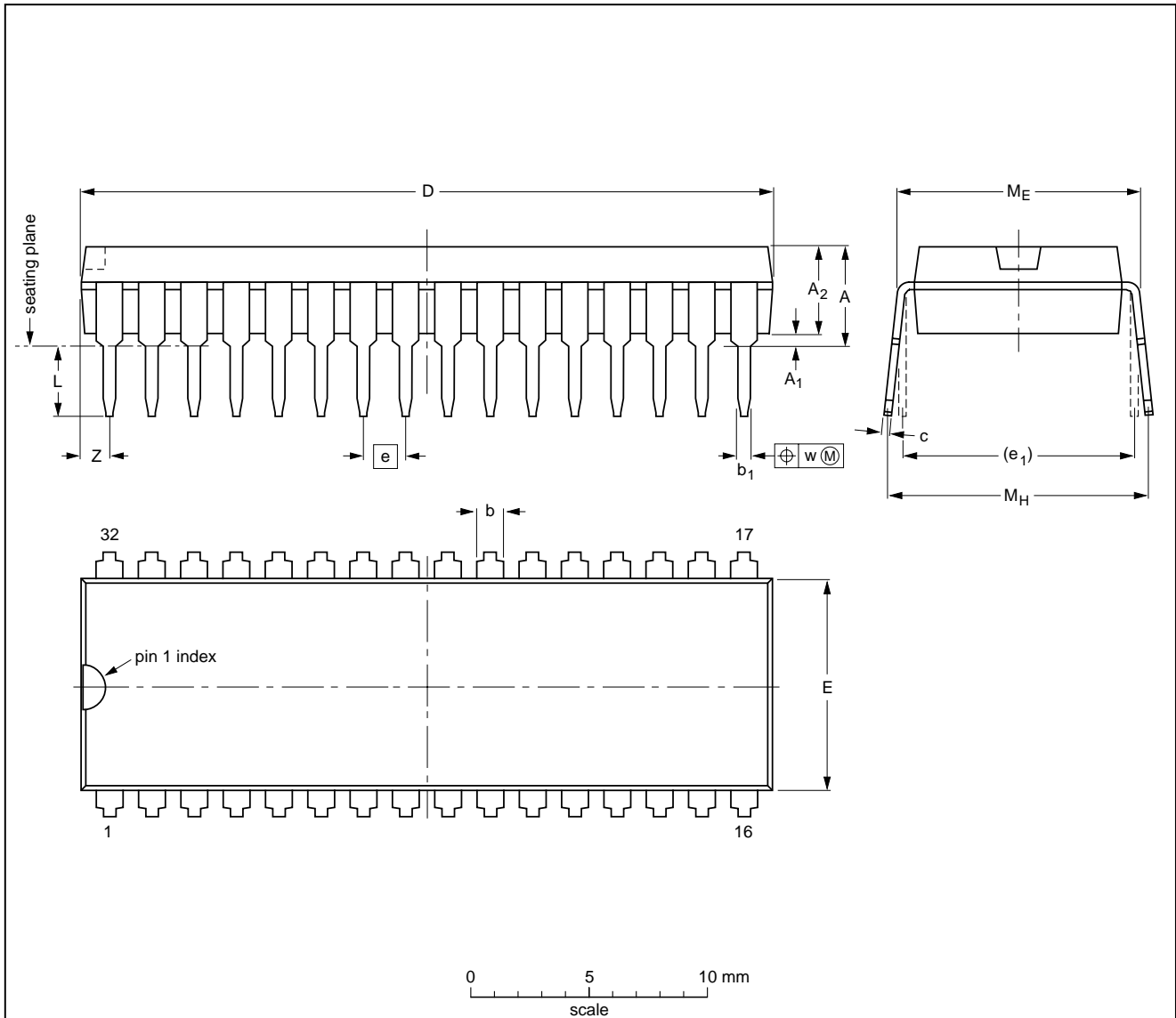

DIMENSIONS (mm are the original dimensions)

UNIT	A max.	A <sub>1</sub> min.	A <sub>2</sub> max.	b	b <sub>1</sub>	c	D <sup>(1)</sup>	E <sup>(1)</sup>	e	e <sub>1</sub>	L	M <sub>E</sub>	M <sub>H</sub>	w	Z <sup>(1)</sup> max.
mm	4.7	0.51	3.8	1.3 0.8	0.53 0.40	0.32 0.23	29.4 28.5	9.1 8.7	1.778	10.16	3.2 2.8	10.7 10.2	12.2 10.5	0.18	1.6

Note

1. Plastic or metal protrusions of 0.25 mm maximum per side are not included.

OUTLINE VERSION	REFERENCES				EUROPEAN PROJECTION	ISSUE DATE
	IEC	JEDEC	EIAJ			
SOT232-1						92-11-17 95-02-04



## Quasi-split sound processor for all standards

TDA3858

### SOLDERING

#### Introduction

There is no soldering method that is ideal for all IC packages. Wave soldering is often preferred when through-hole and surface mounted components are mixed on one printed-circuit board. However, wave soldering is not always suitable for surface mounted ICs, or for printed-circuits with high population densities. In these situations reflow soldering is often used.

This text gives a very brief insight to a complex technology. A more in-depth account of soldering ICs can be found in our "IC Package Databook" (order code 9398 652 90011).

#### Soldering by dipping or by wave

The maximum permissible temperature of the solder is 260 °C; solder at this temperature must not be in contact

with the joint for more than 5 seconds. The total contact time of successive solder waves must not exceed 5 seconds.

The device may be mounted up to the seating plane, but the temperature of the plastic body must not exceed the specified maximum storage temperature ( $T_{stg\ max}$ ). If the printed-circuit board has been pre-heated, forced cooling may be necessary immediately after soldering to keep the temperature within the permissible limit.

#### Repairing soldered joints

Apply a low voltage soldering iron (less than 24 V) to the lead(s) of the package, below the seating plane or not more than 2 mm above it. If the temperature of the soldering iron bit is less than 300 °C it may remain in contact for up to 10 seconds. If the bit temperature is between 300 and 400 °C, contact may be up to 5 seconds.

### DEFINITIONS

Data sheet status	
Objective specification	This data sheet contains target or goal specifications for product development.
Preliminary specification	This data sheet contains preliminary data; supplementary data may be published later.
Product specification	This data sheet contains final product specifications.
Limiting values	
Limiting values given are in accordance with the Absolute Maximum Rating System (IEC 134). Stress above one or more of the limiting values may cause permanent damage to the device. These are stress ratings only and operation of the device at these or at any other conditions above those given in the Characteristics sections of the specification is not implied. Exposure to limiting values for extended periods may affect device reliability.	
Application information	
Where application information is given, it is advisory and does not form part of the specification.	

### LIFE SUPPORT APPLICATIONS

These products are not designed for use in life support appliances, devices, or systems where malfunction of these products can reasonably be expected to result in personal injury. Philips customers using or selling these products for use in such applications do so at their own risk and agree to fully indemnify Philips for any damages resulting from such improper use or sale.