

COMPLETE TV SOUND CHANNEL

The TDA 1190Z is a monolithic integrated circuit in a 12-lead quad in-line plastic package. It performs all the functions needed for the TV sound channel :

- IF LIMITER-AMPLIFIER
- ACTIVE LOW-PASS FILTER
- FM DETECTOR
- DC VOLUME CONTROL
- AF PREAMPLIFIER
- AF OUTPUT STAGE

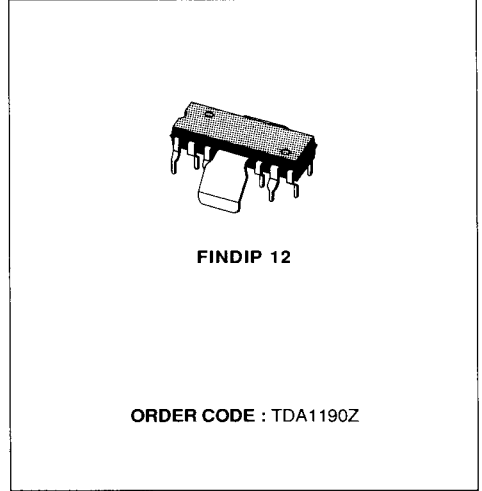

DESCRIPTION

The TDA 1190Z can give an output power of 4.2 W ($d = 10\%$) into a $16\ \Omega$ load at $V_s = 24\text{ V}$, or 1.5 W ($d = 10\%$) into an $8\ \Omega$ load at $V_s = 12\text{ V}$. This performance, together with the FM-IF section characteristics of high sensitivity, high AM rejection and low distortion, enables the device to be used in almost every type of television receivers.

The device has no irradiation problems, hence no external screening is needed.

CONNECTION DIAGRAM (top view)

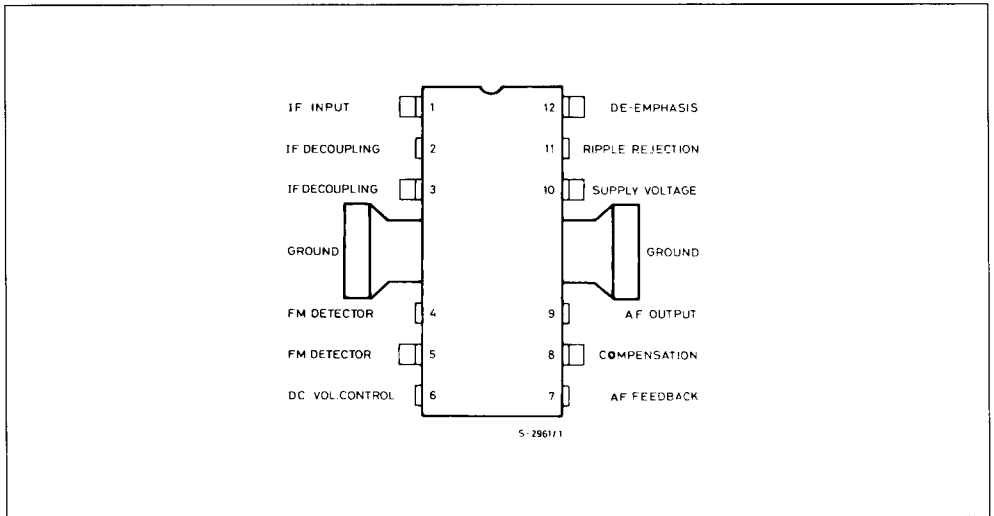

ABSOLUTE MAXIMUM RATINGS

| Symbol | Parameter | Value | Unit |
|----------------|---|-------------|------------------|
| V_s | Supply Voltage (pin 10) | 28 | V |
| V_i | Input Signal Voltage (pin 1) | 1 | V |
| I_o | Output Peak current (non-repetitive) | 2 | A |
| I_o | Output Peak Current (repetitive) | 1.5 | A |
| P_{tot} | Power Dissipation : at $T_{tab} = 90\text{ }^\circ\text{C}$ | 5 | W |
| | at $T_{amb} = 80\text{ }^\circ\text{C}$ (free air) | 1 | W |
| T_{stg}, T_j | Storage and Junction Temperature | - 40 to 150 | $^\circ\text{C}$ |

BLOCK DIAGRAM

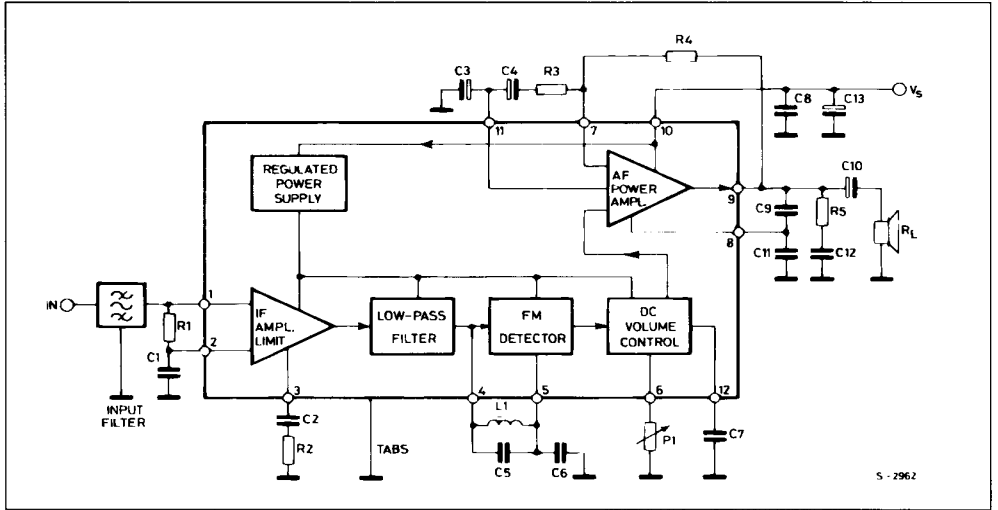

TEST CIRCUIT

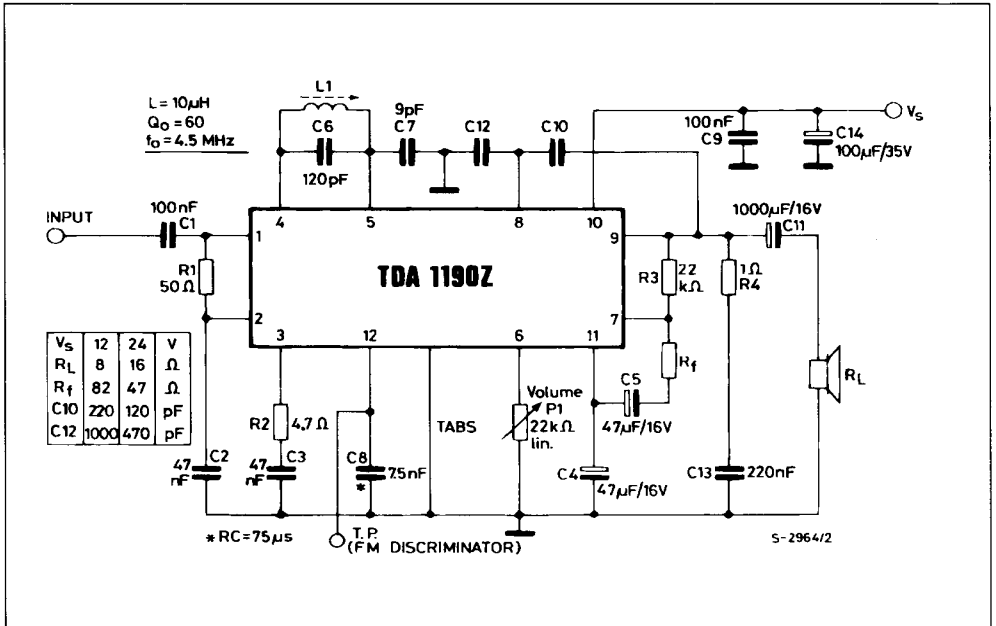

THERMAL DATA

| | | | | |
|----------------|-------------------------------------|-----|-----|---------------|
| $R_{th j-tab}$ | Thermal Resistance Junction-tab | Max | 12 | $^{\circ}C/W$ |
| $R_{th j-amb}$ | Thermal Resistance Junction-ambient | Max | 70* | $^{\circ}C/W$ |

* Obtained with tabs soldered to printed circuit with minimized copper area.

ELECTRICAL CHARACTERISTICS (refer to the test circuit ; $V_s = 24 V$, $T_{amb} = 25 ^{\circ}C$, unless otherwise specified)

| Symbol | Parameter | Test Conditions | Min. | Typ. | Max. | Unit |
|--------|----------------------------------|--|-----------|------------|-----------|------|
| V_s | Supply Voltage (pin 10) | | 9 | | 28 | V |
| V_o | Quiescent Output Voltage (pin 9) | $V_s = 24 V$ $V_s = 12 V$ | 11 5.1 | 12 6 | 13 6.9 | V |
| I_d | Quiescent Drain Current | $P_I = 22 k\Omega$ $V_s = 24 V$ $V_s = 12 V$ | 11 | 22 19 | 45 40 | mA |
| P_o | Output Power | $d = 10 \%$ $f_m = 400 Hz$ $f_o = 4.5 MHz$ $\Delta f = \pm 25 kHz$ $V_s = 24 V$ $R_L = 16 \Omega$ $V_s = 12 V$ $R_L = 8 \Omega$ | | 4.2 1.5 | | W |

ELECTRICAL CHARACTERISTICS (continued)

| Symbol | Parameter | Test Conditions | Min. | Typ. | Max. | Unit |
|-------------------|---|---|------|---------------------------|------|------------------|
| P_o | Output Power | $d = 2\%$ $f_o = 4.5\text{ MHz}$ $V_s = 24\text{ V}$ $V_s = 12\text{ V}$ $f_m = 400\text{ Hz}$ $\Delta f = \pm 25\text{ kHz}$ $R_L = 16\ \Omega$ $R_L = 8\ \Omega$ | | 3.5 1.4 | | W W |
| V_i | Input Limiting Voltage (- 3 dB) at Pin 1 | $f_o = 4.5\text{ MHz}$ $f_m = 400\text{ Hz}$ $\Delta f = \pm 7.5\text{ kHz}$ | | 40 | 100 | μV |
| d | Distortion | $P_o = 50\text{ mW}$ $f_o = 4.5\text{ MHz}$ $V_s = 24\text{ V}$ $V_s = 12\text{ V}$ $f_m = 400\text{ Hz}$ $\Delta f = \pm 7.5\text{ kHz}$ $R_L = 16\ \Omega$ $R_L = 8\ \Omega$ | | 0.75 1 | | % % |
| B | Frequency Response of Audio Amplifier (- 3 dB) | $R_L = 16\ \Omega$ $C_{12} = 470\text{ pF}$ $R_f = 82\ \Omega$ $R_f = 47\ \Omega$ $C_{10} = 120\text{ pF}$ $P_1 = 22\text{ k}\Omega$ | | 70 to 12000 70 to 7000 | | Hz Hz |
| V_o | Recovered Audio Voltage (pin. 12) | $V_i \geq 1\text{ mV}$ $f_m = 400\text{ Hz}$ $P_A = 0$ $f_o = 4.5\text{ MHz}$ $\Delta f = \pm 7.5\text{ kHz}$ | | 120 | | mV |
| AMR | Amplitude Modulation Rejection | $V_i \geq 1\text{ mV}$ $f_m = 400\text{ Hz}$ $m = 0.3$ $f_o = 4.5\text{ MHz}$ $\Delta f = \pm 25\text{ kHz}$ | | 55 | | dB |
| $\frac{S + N}{N}$ | Signal to Noise Ratio | $V_i \geq 1\text{ mV}$ $f_o = 4.5\text{ MHz}$ $\Delta f = \pm 25\text{ kHz}$ $V_o = 4\text{ V}$ $f_m = 400\text{ Hz}$ | 50 | 65 | | dB |
| R_f | External Feedback Resistance (between pins 7 and 9) | | | | 25 | $\text{k}\Omega$ |
| R_i | Input Resistance (pin 1) | $V_i = 1\text{ mV}$ $f_o = 4.5\text{ MHz}$ | | 30 | | $\text{k}\Omega$ |
| C_i | Input Capacitance (pin 1) | | | 5 | | pF |
| SVR | Supply Voltage Rejection | $R_L = 16\ \Omega$ $f_{\text{ripple}} = 120\text{ Hz}$ $P_1 = 22\text{ k}\Omega$ | | 46 | | dB |
| A | DC Volume Control Attenuation | $P_1 = 12\text{ k}\Omega$ | | 90 | | dB |

Figure 1 : Relative Audio Output Voltage and Out-Noise vs. Input Signal.

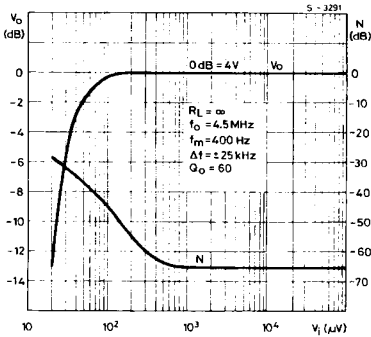

Figure 2 : Output Voltage Attenuation vs. DC Volume Control Resistance.

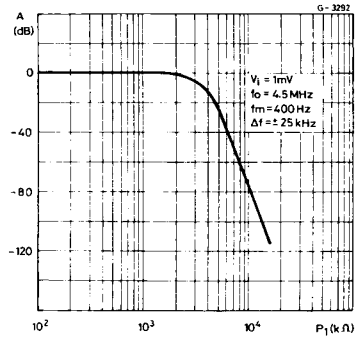

Figure 3 : Amplitude Modulation Rejection vs. Input Signal.

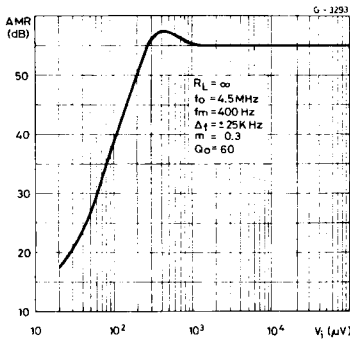

Figure 4 : Δ AMR vs. Tuning Frequency Change.

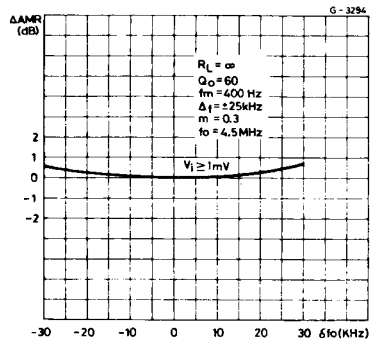

Figure 5 : Recovered Audio Voltage vs. Unloaded Q Factor of the Detector Coil.

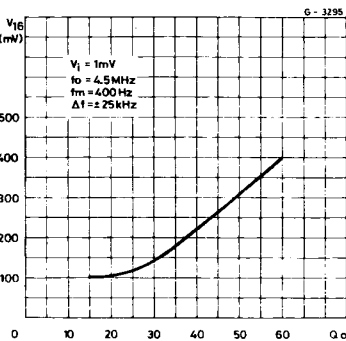

Figure 6 : Distortion vs. Output Power.

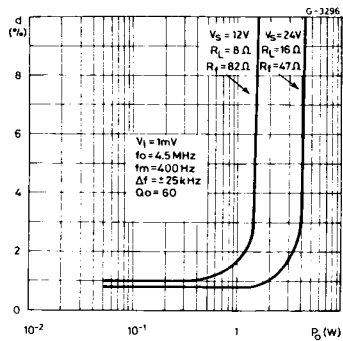

Figure 7 : Distortion vs. Frequency Deviation.

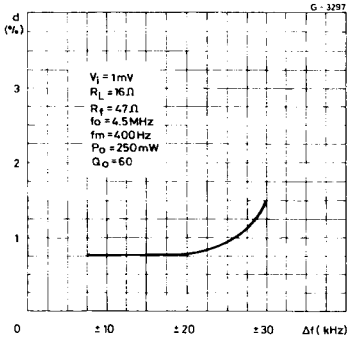

Figure 8 : Distortion vs. Tuning Frequency Change.

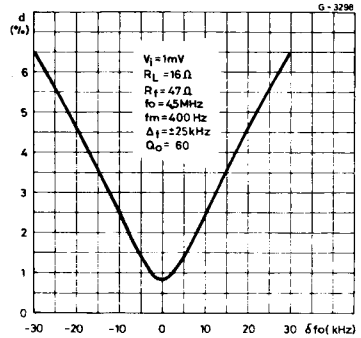

Figure 9 : Audio Amplifier Frequency Response.

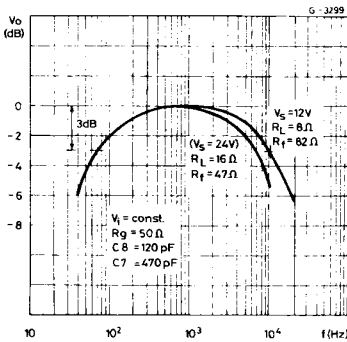

Figure 10 : Supply Voltage Ripple Rejection vs. Ripple Frequency.

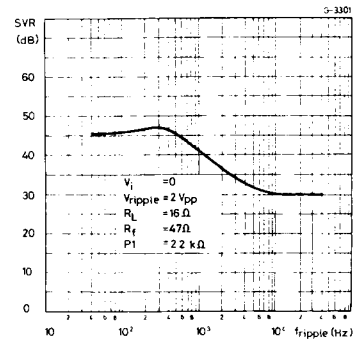

Figure 11 : Supply Voltage Ripple Rejection vs. Volume Control Attenuation.

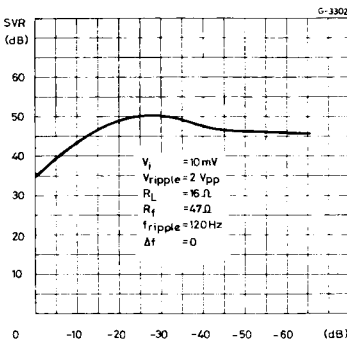

Figure 12 : Output Power vs. Supply Voltage.

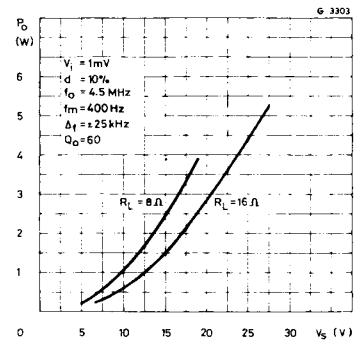

Figure 13 : Maximum Power Dissipation vs. Supply Voltage (sine wave operation).

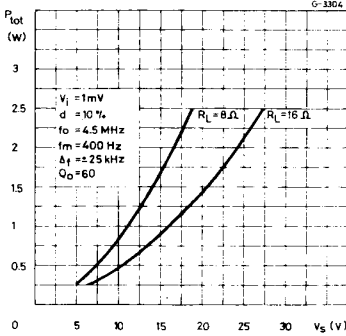

Figure 14 : Power Dissipation and Efficiency vs. Output Power.

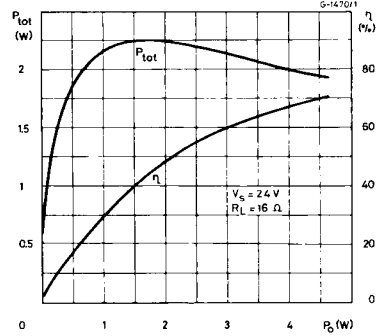
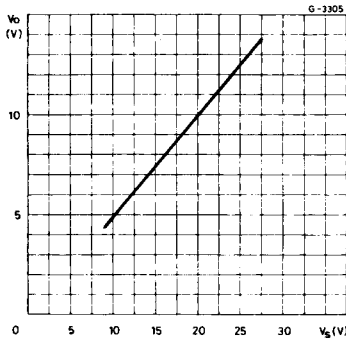

Figure 15 : Quiescent Output Voltage (pin 9) vs. Supply Voltage.



APPLICATION INFORMATION

The electrical characteristics of the TDA 1190Z remain almost constant over the frequency range of 4.5 to 6 MHz, therefore it can be used in all television standard (FM mod.). The TDA 1190Z has a high input impedance, so it can work with a ceramic filter or with a tuned circuit that provide the necessary input selectivity.

The value of the resistors connected to pin 7, determine the AC gain of the audio frequency amplifier. This enables the desired gain to be selected in relation to the frequency deviation at which the output stage of the AF amplifier must enter into clipping.

The capacitor connected between pins 9 and 8 determines the upper cut-off frequency of the audio band. If larger bandwidth is required C_{10} , C_{12} must be reduced keeping C_{12}/C_{10} as in fig. 16.

The capacitor connected between pin 12 and ground, together with the internal resistor of $10 K\Omega$, forms the de-emphasis network. The Boucherot cell eliminates the high frequency oscillations caused by inductive load and the wires connecting the loud-speaker.

Figure 16 : Typical Application Circuit.

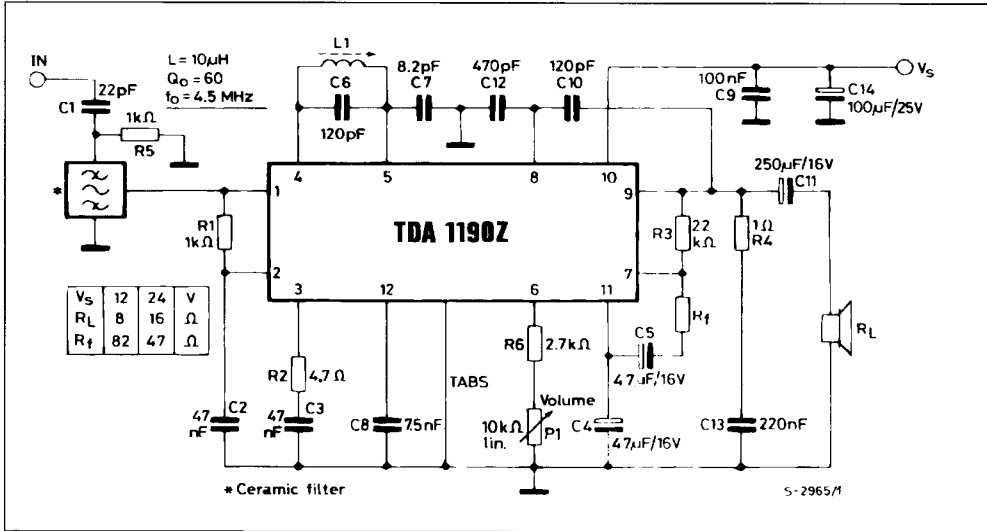
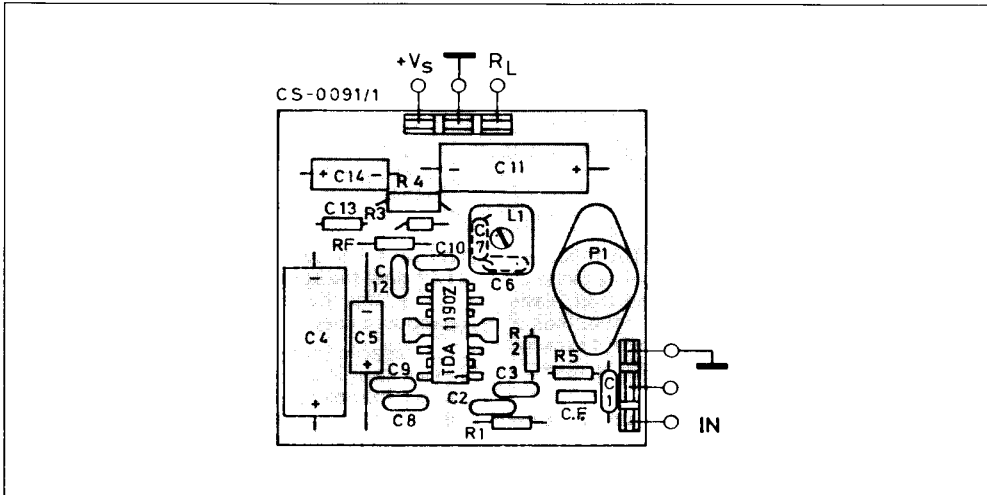

Figure 17 : P.C. Board and Component Layout of the Circuit Shown in Fig. 16.



MOUNTING INSTRUCTION

The $R_{th\ j-amb}$ of the TDA1190Z can be reduced by soldering the tabs to a suitable copper area of the printed circuit board (fig. 18) or to an external heat-sink (fig. 19).

The diagram of figure 20 shows the maximum dissipated power P_{tot} and the $R_{th\ j-amb}$ as a function of the side "l" of two equal square copper areas having a thickness of $35\ \mu$ (1.4 mils).

During soldering the tab temperature must not exceed $260\ ^\circ\text{C}$ and the soldering time must not be longer than 12 seconds.

The external heatsink or printed circuit copper area must be connected to electrical ground.

Figure 18 : Example of P.C. Board Copper Area Which is Used as Heatsink.

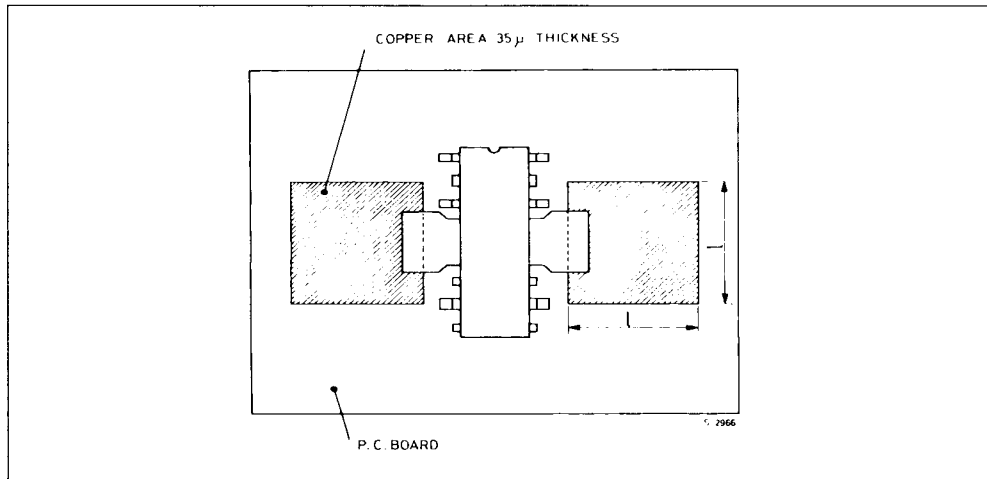

Figure 19 : External Heatsink Mounting Example.

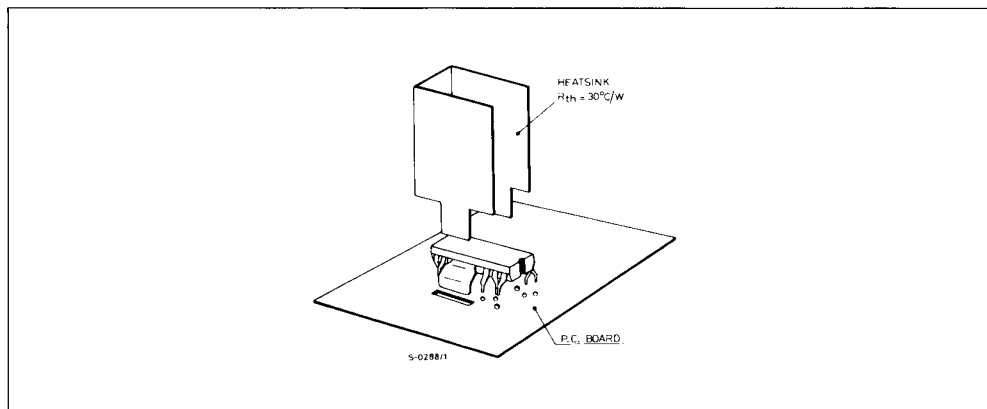

Figure 20 : Maximum Dissipable Power and Junction to Ambient Thermal Resistance vs. Side "I" .

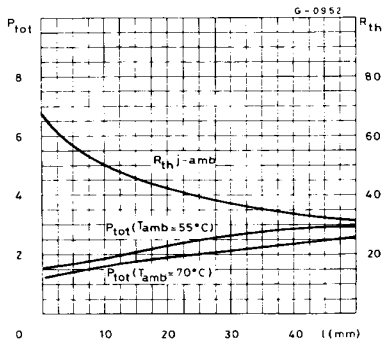

Figure 21 : Maximum Allowable Power Dissipation vs. Ambient Temperature.

