

REF02

+5V Precision VOLTAGE REFERENCE

FEATURES

- **OUTPUT VOLTAGE:** +5V $\pm 0.1\%$ max
- **EXCELLENT TEMPERATURE STABILITY:**
8.5ppm/ $^{\circ}\text{C}$ max (-40°C to $+85^{\circ}\text{C}$)
8.5ppm/ $^{\circ}\text{C}$ max (-55°C to $+125^{\circ}\text{C}$)
- **LOW NOISE:** 10 μV p-p max (0.1Hz to 10Hz)
- **EXCELLENT LINE REGULATION:**
0.008%/V max
- **EXCELLENT LOAD REGULATION:**
0.005%/mA max
- **LOW SUPPLY CURRENT:** 1.4mA max
- **SHORT-CIRCUIT PROTECTED**
- **WIDE SUPPLY RANGE:** 8V to 40V
- **EXTENDED INDUSTRIAL TEMPERATURE RANGE:** -40°C to $+85^{\circ}\text{C}$
- **PACKAGE OPTIONS:** Hermetic TO-99, Plastic DIP, Cerdip, SOIC

APPLICATIONS

- PRECISION REGULATORS
- CONSTANT CURRENT SOURCE/SINK
- DIGITAL VOLTMETERS
- V/F CONVERTERS
- A/D AND D/A CONVERTERS
- PRECISION CALIBRATION STANDARD
- TEST EQUIPMENT

DESCRIPTION

The REF02 is a precision 5V voltage reference. The drift is laser trimmed to 8.5ppm/ $^{\circ}\text{C}$ max over the extended industrial and military temperature range. The REF02 provides a stable 5V output that can be externally adjusted over a $\pm 6\%$ range with minimal effect on temperature stability. REF02 operates from a single supply with an input range of 8V to 40V with a very low current drain of 1mA, and excellent temperature stability due to an improved design. Excellent line and load regulation, low noise, low power, and low cost make the REF02 the best choice whenever a 5V voltage reference is required. All popular package options are available: hermetic TO-99, ceramic DIP, plastic DIP, and SOIC. The REF02 is an ideal choice for portable instrumentation, temperature transducers, A/D and D/A converters, and digital voltmeter.

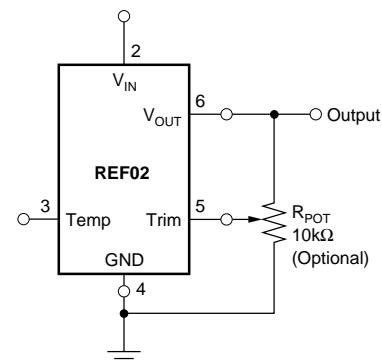

SPECIFICATIONS

ELECTRICAL

$T_A = +25^\circ\text{C}$ and $V_{IN} = +15\text{V}$ power supply unless otherwise noted.

PARAMETER	CONDITIONS	REF02A, R			REF02B, S			REF02C			UNITS
		MIN	TYP	MAX	MIN	TYP	MAX	MIN	TYP	MAX	
OUTPUT VOLTAGE Change with Temperature ^(1,2) (ΔV_{OT}) -40°C to +85°C -55°C to +125°C	$I_{LOAD} = 0\text{mA}$	4.985	5.0	5.015	4.990	*	5.010	4.995	*	5.005	V
			0.05	0.19		0.05	0.13		0.05	0.11	%
			0.05	0.27		0.05	0.15				%
OUTPUT VOLTAGE DRIFT ⁽³⁾ -40°C to +85°C (TCV _O) -55°C to +125°C			4	15		4	10		4	8.5	$\pm\text{ppm}/^\circ\text{C}$
			4	15		4	8.5				$\pm\text{ppm}/^\circ\text{C}$
OUTPUT ADJUSTMENT RANGE	$R_{POT} = 10\text{k}\Omega$ ⁽⁶⁾	± 3	± 6		*	*		*	*		%
CHANGE IN V_O TEMP COEFFICIENT WITH OUTPUT ADJUSTMENT (-55°C to +125°C)	$R_{POT} = 10\text{k}\Omega$		0.7			*			*		ppm/%
OUTPUT VOLTAGE NOISE	0.1Hz to 10Hz ⁽⁵⁾		4	10		*	*		*	*	$\mu\text{Vp-p}$
LINE REGULATION ⁽⁴⁾ -40°C to +85°C -55°C to +125°C	$V_{IN} = 8\text{V to }33\text{V}$		0.006	0.010		*	*		0.004	0.008	%/V
	$V_{IN} = 8.5\text{V to }33\text{V}$		0.008	0.012		*	*		0.005	0.010	
	$V_{IN} = 9\text{V to }33\text{V}$		0.009	0.015		*	*				
LOAD REGULATION ⁽⁴⁾ -40°C to +85°C -55°C to +125°C	$I_L = 0\text{mA to }+10\text{mA}$		0.005	0.010		*	0.008		0.003	0.005	%/mA
	$I_L = 0\text{mA to }+10\text{mA}$		0.007	0.012		*	0.010		0.004	0.005	
	$I_L = 0\text{mA to }+10\text{mA}$		0.008	0.015		*	0.012				
TURN-ON SETTLING TIME	To $\pm 0.1\%$ of Final Value		5			*			*		μs
QUIESCENT CURRENT	No Load		1.0	1.4		*	*		*	*	mA
LOAD CURRENT (SOURCE)		10	21		*	*		*	*		mA
LOAD CURRENT (SINK)		-0.3	-0.5		*	*		*	*		mA
SHORT-CIRCUIT CURRENT	$V_{OUT} = 0$		30			*			*		mA
POWER DISSIPATION	No Load		15	21		*	*		*	*	mW
TEMPERATURE VOLTAGE OUTPUT ⁽⁷⁾			630			*			*		mV
TEMPERATURE COEFFICIENT of Temperature Pin Voltage -55°C to +125°C			2.1								mV/ $^\circ\text{C}$
TEMPERATURE RANGE Specification REF02A, B, C REF02R, S		-40		+85	*		*	*		*	$^\circ\text{C}$
		-55		+125	*		*				$^\circ\text{C}$

NOTES: (1) ΔV_{OT} is defined as the absolute difference between the maximum output and the minimum output voltage over the specified temperature range expressed as a percentage of 5V: $\Delta V_O = \frac{|V_{MAX} - V_{MIN}|}{5\text{V}} \times 100$ (2) ΔV_{OT} specification applies trimmed to +5.000V or untrimmed. (3) TCV_O is defined as ΔV_{OT} divided

by the temperature range. (4) Line and load regulation specifications include the effect of self heating. (5) Sample tested. (6) 10k Ω potentiometer connected between V_{OUT} and ground with wiper connected to Trim pin. See Figure on page 1. (7) Pin 3 is insensitive to capacitive loading. The temperature voltage will be modified by 7mV for each μA of loading.

The information provided herein is believed to be reliable; however, BURR-BROWN assumes no responsibility for inaccuracies or omissions. BURR-BROWN assumes no responsibility for the use of this information, and all use of such information shall be entirely at the user's own risk. Prices and specifications are subject to change without notice. No patent rights or licenses to any of the circuits described herein are implied or granted to any third party. BURR-BROWN does not authorize or warrant any BURR-BROWN product for use in life support devices and/or systems.

ABSOLUTE MAXIMUM RATINGS

Input Voltage	+40V
Operating Temperature	
G, P, U	-40°C to +85°C
M	-55°C to +125°C
Storage Temperature Range	
G, P, U	-65°C to +125°
M	-65°C to +150°
Output Short Circuit Duration (to Ground or V_{IN})	Indefinite
Junction Temperature	-65°C to +150°
θ_{JA} P, G	120°C/W
U	80°C/W
M	150°C/W
Lead Temperature (soldering, 60s)	+300°C

PIN CONFIGURATIONS

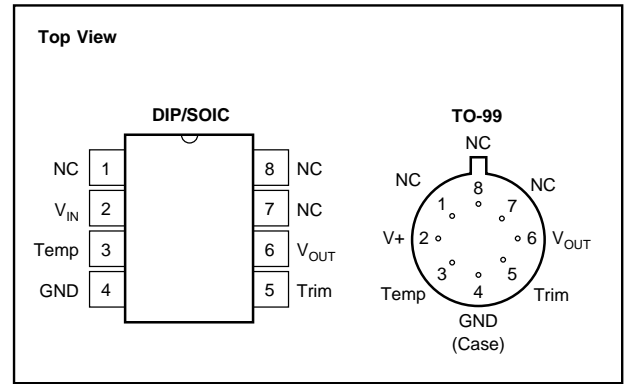

PACKAGE INFORMATION⁽¹⁾

MODEL	PACKAGE	PACKAGE DRAWING NUMBER
REF02AU	SOIC	182
REF02BU	SOIC	182
REF02AP	Plastic DIP	006
REF02BP	Plastic DIP	006
REF02AG	Cerdip	161
REF02BG	Cerdip	161
REF02AM	Metal TO-99	001
REF02BM	Metal TO-99	001
REF02CM	Metal TO-99	001
REF02RM	Metal TO-99	001
REF02SM	Metal TO-99	001

NOTE: (1) For detailed drawing and dimension table, please see end of data sheet, or Appendix D of Burr-Brown IC Data Book.

ORDERING INFORMATION

MODEL	V_{OUT} AT 25°C	MAX DRIFT (ppm/°C)	TEMPERATURE	PACKAGE
REF02AU	5V±15mV	±15	-40°C to +85°C	SOIC
REF02BU	5V±10mV	±10	-40°C to +85°C	SOIC
REF02AP	5V±15mV	±15	-40°C to +85°C	Plastic DIP
REF02BP	5V±10mV	±10	-40°C to +85°C	Plastic DIP
REF02AG	5V±15mV	±15	-40°C to +85°C	Cerdip
REF02BG	5V±10mV	±10	-40°C to +85°C	Cerdip
REF02AM	5V±15mV	±15	-40°C to +85°C	Metal TO-99
REF02BM	5V±10mV	±10	-40°C to +85°C	Metal TO-99
REF02CM	5V±5mV	±8.5	-40°C to +85°C	Metal TO-99
REF02RM	5V±15mV	±15	-55°C to +125°C	Metal TO-99
REF02SM	5V±10mV	±8.5	-55°C to +125°C	Metal TO-99

DICE INFORMATION

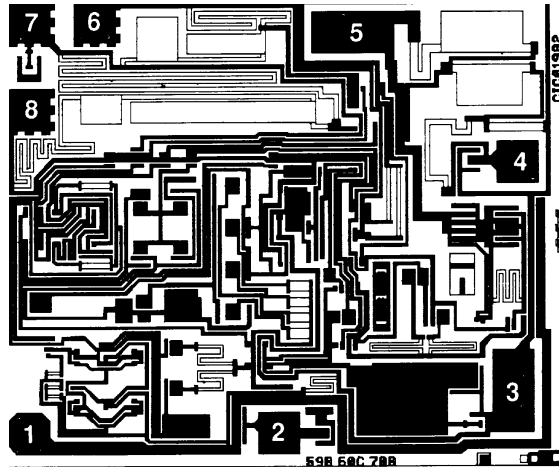

REF02 DIE TOPOGRAPHY

PAD	FUNCTION	PAD	FUNCTION
1	V_{IN}	5	V_{OUT}
2	Temp	6	NC
3	GND	7	NC
4	Trim	8	NC

Substrate Bias: -V

MECHANICAL INFORMATION

	MILS (0.001")	MILLIMETERS
Die Size	73 x 62	1.85 x 1.57
Die Thickness	14 ±3	0.36 ± 0.08
Min. Pad Size	5 x 5	0.10 x 0.10
Gold Backing		

TYPICAL PERFORMANCE CURVES

$T_A = +25^\circ\text{C}$ unless otherwise noted.

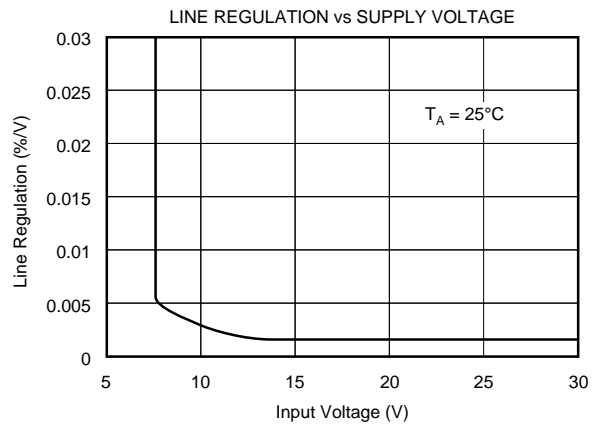
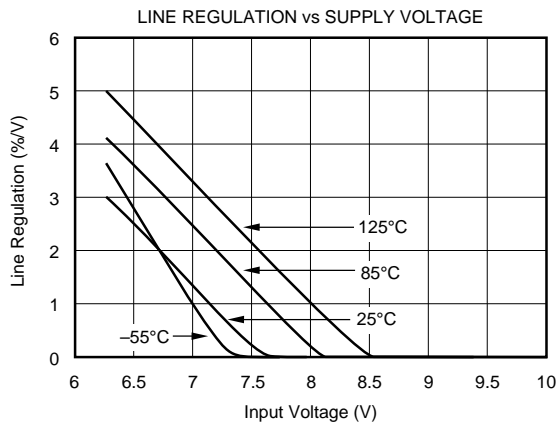
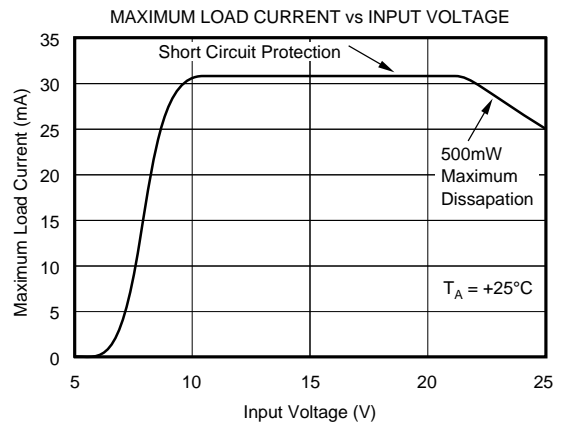
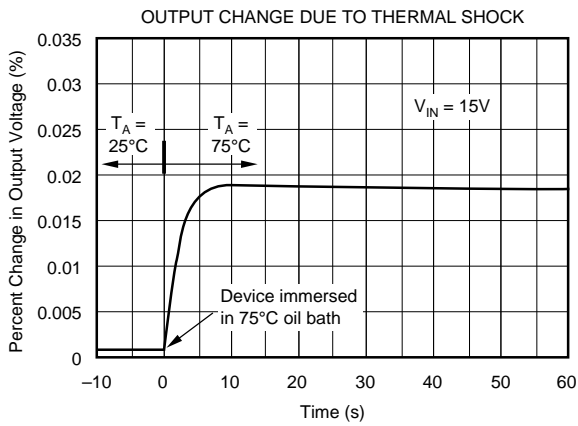
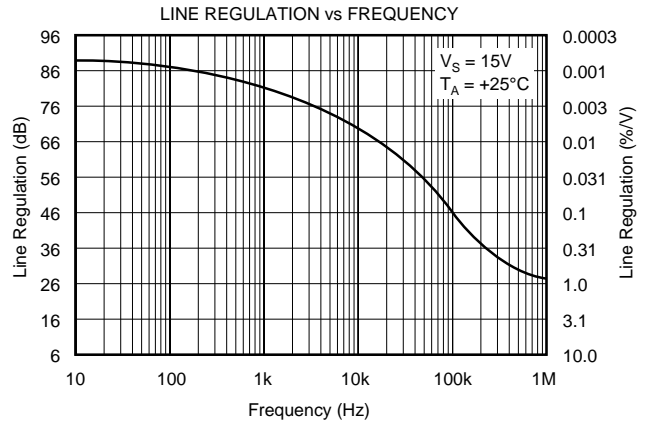
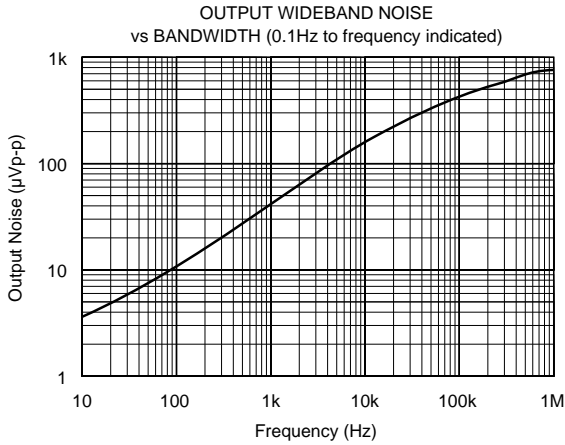

TYPICAL PERFORMANCE CURVES (CONT)

$T_A = +25^\circ\text{C}$ unless otherwise noted.

NORMALIZED LOAD REGULATION ($\Delta I_L = 10\text{mA}$)
vs TEMPERATURE

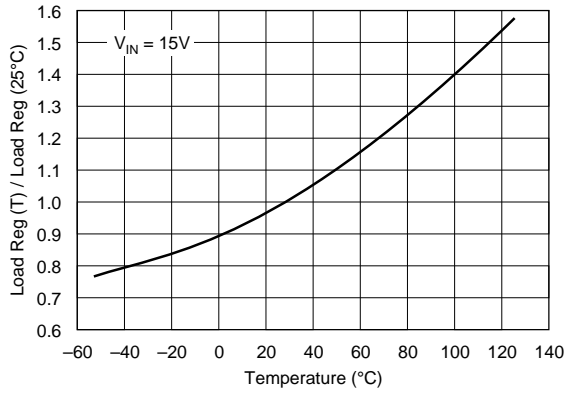

NORMALIZED LINE REGULATION vs TEMPERATURE

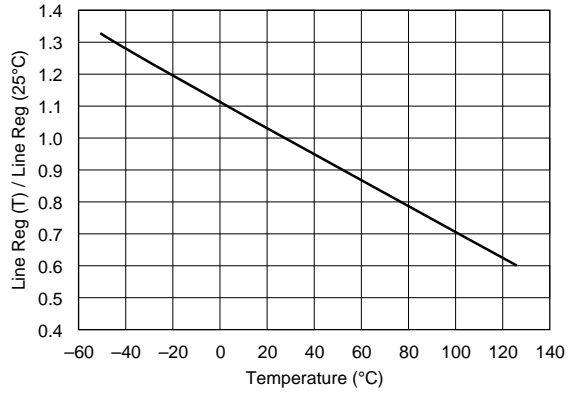

REF02 V_{OUT}

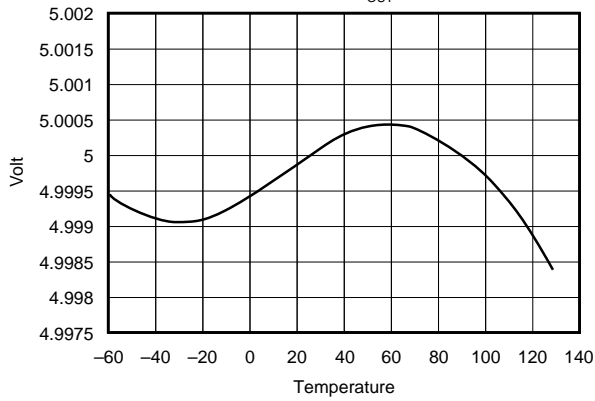

MAXIMUM LOAD CURRENT vs TEMPERATURE

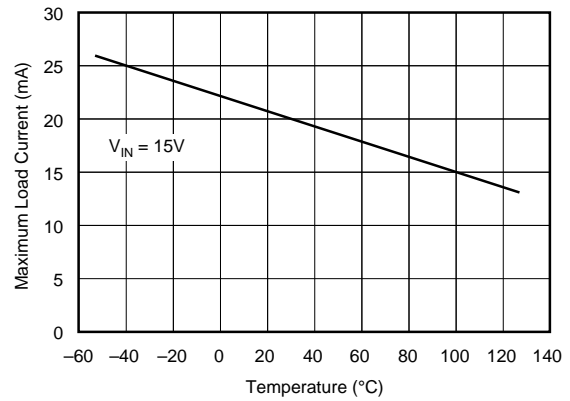

QUIESCENT CURRENT vs TEMPERATURE

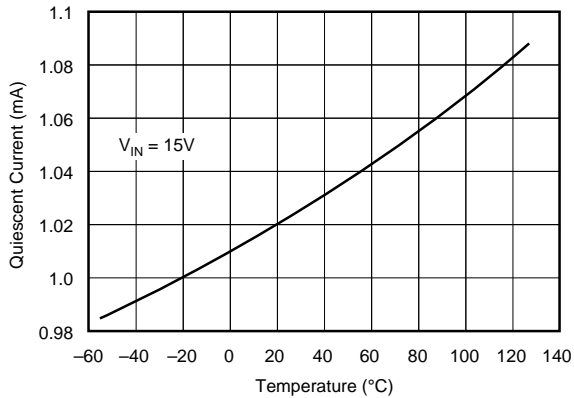

TYPICAL TEMPERATURE VOLTAGE OUTPUT
vs TEMPERATURE (REF02M)

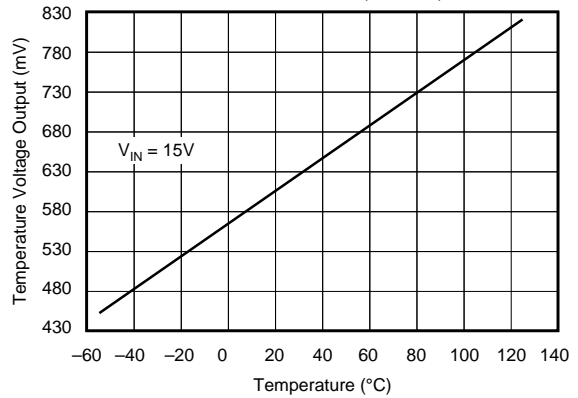

OUTPUT ADJUSTMENT

The REF02 trim terminal can be used to adjust the voltage over a $5V \pm 150mV$ range. This feature allows the system designer to trim system errors by setting the reference to a voltage other than 5V, including $5.12V^{(1)}$ for binary applications (see circuit on page one).

Adjustment of the output does not significantly affect the temperature performance of the device. The temperature coefficient change is approximately $0.7ppm/^{\circ}C$ for $100mV$ of output adjustment.

NOTE: (1) 20mV LSB for 8-bit applications.

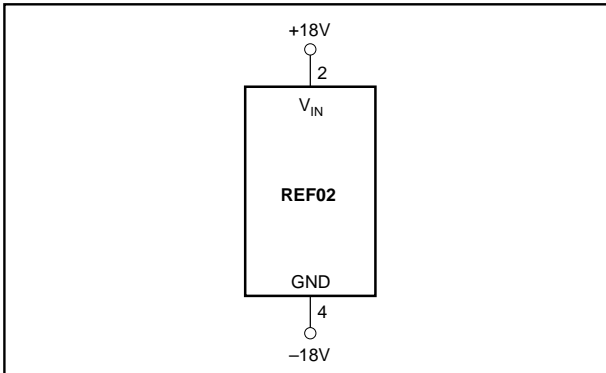

FIGURE 1. Burn-In Circuit.

TYPICAL APPLICATIONS

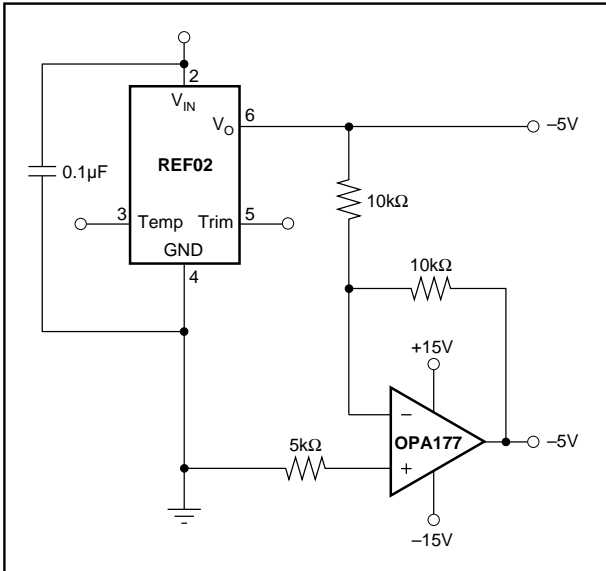

FIGURE 2. $\pm 5V$ Precision Reference.

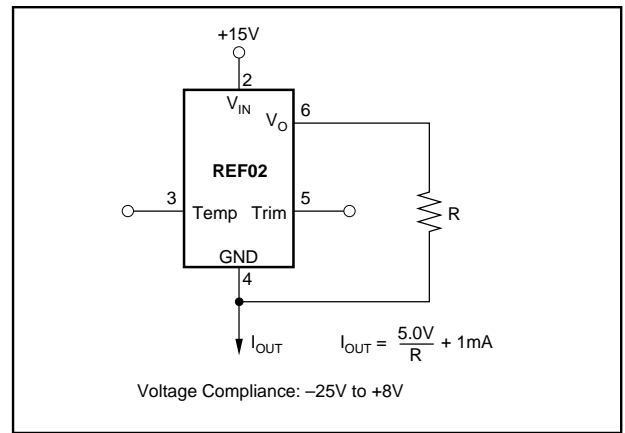

FIGURE 3. Current Source.

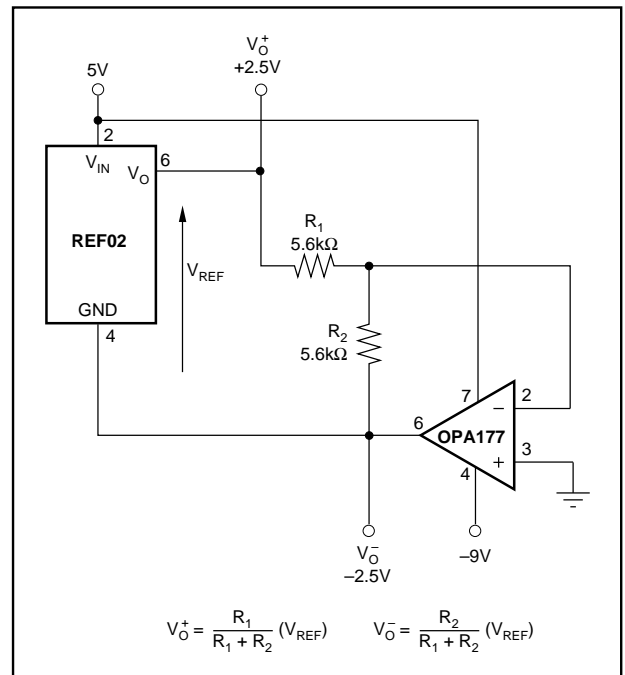

FIGURE 4. $\pm 2.5V$ Precision Reference.

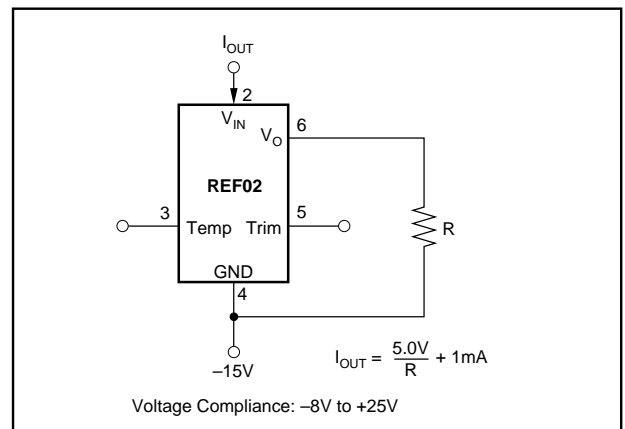

FIGURE 5. Current Sink.

REFERENCE STACKING PROVIDES OUTSTANDING LINE REGULATION

By stacking two REF01s and one REF02, a systems designer can achieve 5V, 15V and 25V outputs. One very important advantage of this circuit is the near perfect line regulation at 5V and 15V outputs. This circuit can accept a 27V to 55V change to the input with less than the noise voltage as a change to the output voltage. (R_B), a load bypass resistor, supplies current (I_{SV}) for the 15V regulator.

Any number of REF01s and REF02s can be stacked in this configuration. If ten devices can be stacked in this configuration, for example, ten 5V or five 10V outputs are achieved. The line voltage may range from 100V to 130V. Care should be exercised to insure that the total load currents do not exceed the maximum usable current which is typically 21mA.

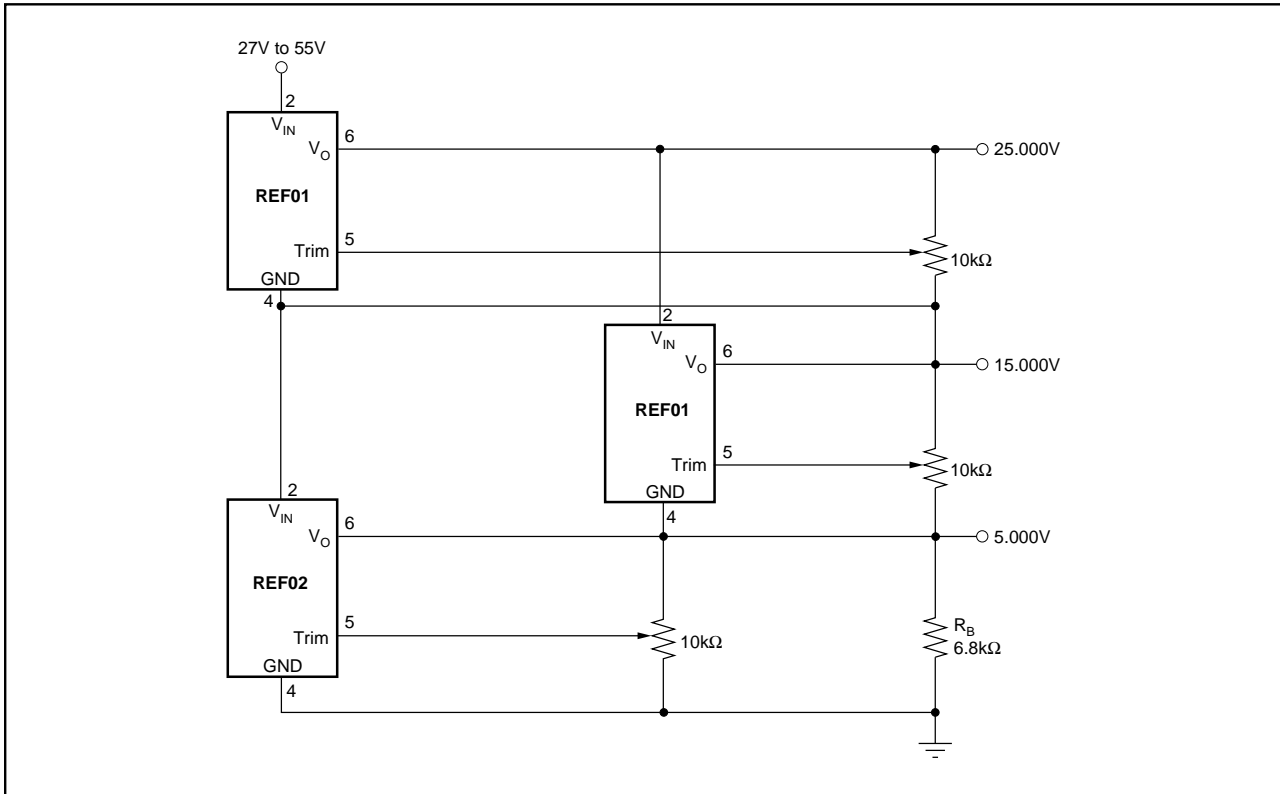
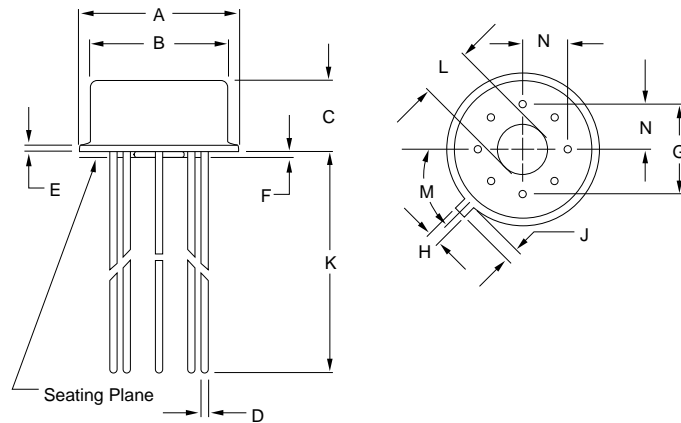

FIGURE 6. Reference Stack.

MECHANICALS

Package Number 001 — Metal TO-99



DIM	INCHES		MILLIMETERS	
	MIN	MAX	MIN	MAX
A	.335	.370	8.51	9.40
B	.305	.335	7.75	8.51
C	.165	.185	4.19	4.70
D	.016	.021	0.41	0.53
E	.010	.040	0.25	1.02
F	.010	.040	0.25	1.02
G	.200 BASIC		5.08 BASIC	
H	.028	.034	0.71	0.86
J	.029	.045	0.74	1.14
K	.500	—	12.7	—
L	.110	.160	2.79	4.06
M	45° BASIC		45° BASIC	
N	.095	.105	2.41	2.67

NOTE: Leads in true position within 0.01" (0.25mm) R at MMC at seating plane. Tab is pin 8.

Package Number 006 — 8-Pin Plastic Single-Wide DIP

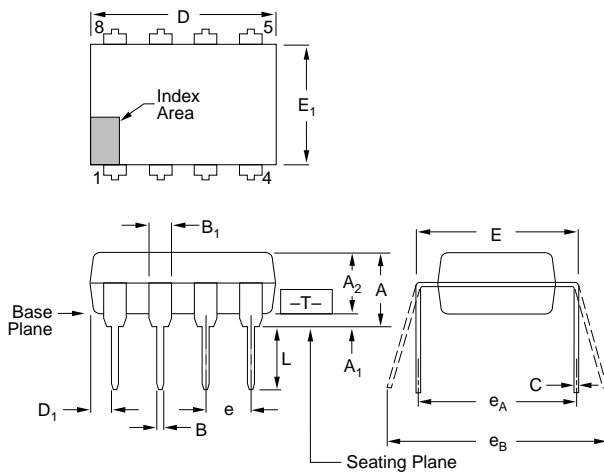

DIM	INCHES		MILLIMETERS	
	MIN	MAX	MIN	MAX
A ⁽³⁾	—	.210	—	5.33
A1 ⁽³⁾	.015	—	0.38	—
A2	.115	.195	2.92	4.95
B	.014	.022	0.36	0.56
B1	.045	.070	1.14	1.78
C	.008	.015	0.20	0.38
D ⁽⁴⁾	.348	.430	8.84	10.92
D1	.005	—	0.13	—
E ⁽⁵⁾	.300	.325	7.62	8.26
E1 ⁽⁴⁾	.240	.280	6.10	7.11
e	.100 BASIC		2.54 BASIC	
eA ⁽⁵⁾	.300 BASIC		7.63 BASIC	
eB ⁽⁶⁾	—	.430	—	10.92
L ⁽⁸⁾	.115	.160	2.92	4.06
N ⁽⁷⁾	8		8	

(2) Dimensioning and tolerancing per ANSI Y14.5M-1982.

(3) Dimensions A, A1, and L are measured with the package seated in JEDEC seating plane gauge GS-3.

(4) D and E1 dimensions for plastic packages do not include mold flash or protrusions. Mold flash or protrusions shall not exceed .010 inch (0.25mm).

(5) E and eA measured with the leads constrained to be perpendicular to plane T.

(6) eB is measured at the lead tips with the leads unconstrained.

(7) N is the maximum number of terminal positions.

(8) Corner leads (1, 4, 5, and 8) may be configured as shown in Figure 2.

(9) For automatic insertion, any raised irregularity on the top surface (step, mesa, etc.) shall be symmetrical about the lateral and longitudinal package center-lines.

(1) Controlling dimension: Inch. In case of conflict between the English and metric dimensions, the inch dimensions control.

Package Number 182 — 8-Pin SO-8 Surface Mount

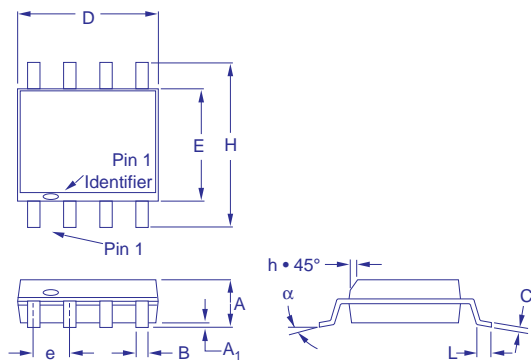

DIM	INCHES		MILLIMETERS	
	MIN	MAX	MIN	MAX
A	.054	.068	1.37	1.73
A1	.004	.009	0.10	0.23
B	.014	.019	0.36	0.48
C	.008	.0098	0.20	0.25
D	.189	.196	4.80	4.98
E	.150	.157	3.81	3.99
e	.050 BASIC		1.27 BASIC	
H	.229	.244	5.82	6.20
h	.010	.019	0.25	0.48
L	.016	.050	0.41	1.27
N	8		8	
α	0°	8°	0°	8°

NOTES:

1. Dimensioning and tolerancing per ANSI Y14.5M-1982.

2. "D" and "E" are reference datums and do not include mold flash or protrusions. Mold flash or protrusions shall not exceed 0.15mm (.086 in.)

3. The chamfer on the body is optional. If it is not present, a visual index feature must be located within the cross-hatched area.

4. "L" is the length of the terminal for soldering to a substrate.

5. "N" is the number of terminal positions.

MECHANICALS (CONT)

Package Number 161 — 8-Pin Ceramic

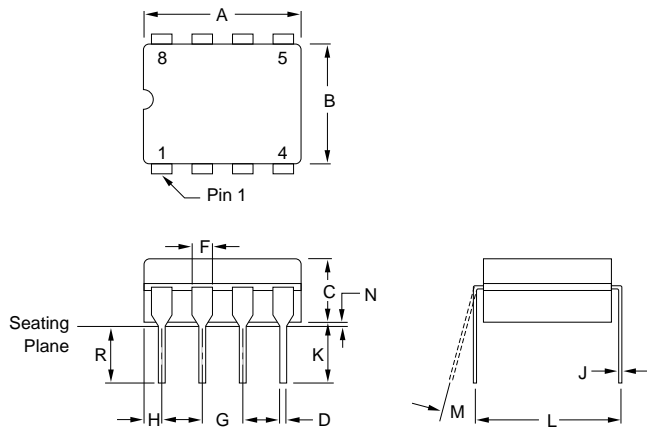

DIM	INCHES		MILLIMETERS	
	MIN	MAX	MIN	MAX
A	.375	.405	9.53	10.28
B	.280	.295	7.11	7.50
C	.140	.170	3.56	4.32
D	.015	.021	0.38	0.53
F	.045	.060	1.14	1.52
G	.100 BASIC		2.54 BASIC	
H	—	.098	—	2.49
J	.008	.012	0.20	0.30
K	.150	—	3.80	—
L	.290	.320	7.37	8.13
M	0°	15°	0°	15°
N	.009	.060	0.23	1.52
R	.125	.175	3.18	4.45

NOTE: Leads in true position within 0.01" (0.25mm) R at MMC at seating plane. Pin numbers shown for reference only. Numbers may not be marked on the package.