

# REF01

## +10V Precision VOLTAGE REFERENCE

### FEATURES

- **OUTPUT VOLTAGE:** +10V  $\pm 0.2\%$  max
- **EXCELLENT TEMPERATURE STABILITY:**  
8.5ppm/ $^{\circ}\text{C}$  max ( $-40^{\circ}\text{C}$  to  $+85^{\circ}\text{C}$ )  
10.0 ppm/ $^{\circ}\text{C}$  max ( $-55^{\circ}\text{C}$  to  $+125^{\circ}\text{C}$ )
- **LOW NOISE:** 5 $\mu\text{Vp-p}$  typ (0.1Hz to 10Hz)
- **EXCELLENT LINE REGULATION:**  
0.001%/V max
- **EXCELLENT LOAD REGULATION:**  
0.002%/mA max
- **SOURCES 10mA, SINKS 5mA min**
- **LOW SUPPLY CURRENT:** 1.4mA max
- **SHORT-CIRCUIT PROTECTED**
- **WIDE SUPPLY RANGE:** 11.4VDC to 40VDC
- **PACKAGE OPTIONS:** Hermetic TO-99,  
Ceramic DIP, Plastic DIP, SOIC
- **EXTENDED INDUSTRIAL TEMPERATURE  
RANGE:**  $-40^{\circ}\text{C}$  to  $+85^{\circ}\text{C}$

### APPLICATIONS

- PRECISION REGULATORS
- CONSTANT CURRENT SOURCE/SINK
- DIGITAL VOLTMETERS
- A/D AND D/A CONVERTERS
- PRECISION CALIBRATION STANDARD
- TEST EQUIPMENT

### DESCRIPTION

The REF01 is a high performance, low price, precision pin compatible second source voltage reference. Output accuracy of  $\pm 0.2\%$  is a 30% improvement over industry standard REF01s. Output noise is 5 $\mu\text{Vp-p}$ , which is a 75% decrease in noise over all other REF01s. Line regulation is 0.001%/V max and load regulation is 0.002%/mA max, which far exceeds the performance of our competitors. Quiescent current is a low 1.4mA. REF01 provides extended supply range when compared to industry standard devices. Burr-Brown's REF01 is the best choice for applications which requires improved accuracy, low noise, low power consumption, low drift, and the lowest price. Popular package options are available: TO-99, Ceramic DIP, plastic DIP, and SOIC. For guaranteed long-term drift see Burr-Brown's model REF10.

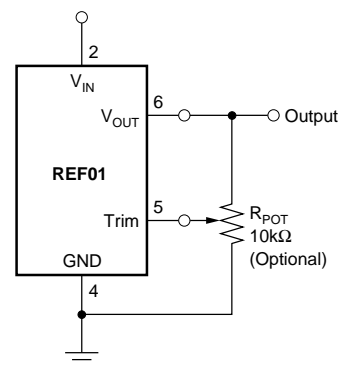

+10V Reference with Trimmed Output

International Airport Industrial Park • Mailing Address: PO Box 11400 • Tucson, AZ 85734 • Street Address: 6730 S. Tucson Blvd. • Tucson, AZ 85706  
Tel: (520) 746-1111 • Twx: 910-952-1111 • Cable: BBRCORP • Telex: 066-6491 • FAX: (520) 889-1510 • Immediate Product Info: (800) 548-6132

# SPECIFICATIONS

## ELECTRICAL

T<sub>A</sub> = +25°C and V<sub>S</sub> = +15V power supply unless otherwise noted.

PARAMETER	CONDITIONS	REF01A, R			REF01B, S			REF01C			UNITS
		MIN	TYP	MAX	MIN	TYP	MAX	MIN	TYP	MAX	
OUTPUT VOLTAGE ( $\Delta V_{OT}$ ) Change with Temperature <sup>(1, 2)</sup> -40°C to +85°C -55°C to +125°C	I <sub>L</sub> = 0mA	9.970	10.0	10.030	9.975	10.0	10.025	9.980	10.0	10.020	V
			0.11	0.18		0.06	0.11		0.04	0.07	%
			0.13	0.22		0.07	0.12				%
OUTPUT VOLTAGE DRIFT <sup>(3)</sup> -40°C to +85°C (TCV <sub>O</sub> ) -55°C to +125°C			10	25		8	15		3	8.5	±ppm/°C
			10	20		8	10				±ppm/°C
OUTPUT ADJUSTMENT RANGE	R <sub>POT</sub> = 10kΩ <sup>(6)</sup>	±3			±3			±3			%
CHANGE IN V <sub>O</sub> TEMP COEFFICIENT WITH OUTPUT ADJUSTMENT (-55°C to +125°C)	R <sub>POT</sub> = 10kΩ		0.5			0.5			0.5		ppm/%
OUTPUT VOLTAGE NOISE	0.1Hz to 10Hz <sup>(5)</sup>		5			5			5		μVp-p
LINE REGULATION <sup>(4)</sup> -40°C to +85°C -55°C to +125°C	V <sub>IN</sub> = 11.4V to 36V		0.001	0.003		0.0007	0.002		0.0003	0.001	%/V
			0.002	0.006		0.001	0.004		0.001	0.002	
			0.004	0.012		0.003	0.008				
LOAD REGULATION <sup>(4)</sup> -40°C to +85°C -55°C to +125°C	I <sub>L</sub> = 0mA to +10mA I <sub>L</sub> = 0mA to -5mA I <sub>L</sub> = 0mA to +10mA I <sub>L</sub> = 0mA to +10mA		0.001	0.004		0.001	0.003		0.001	0.002	%/mA
			0.003	0.008		0.002	0.006		0.001	0.004	
			0.005	0.016		0.004	0.012		0.003	0.008	
			0.008	0.024		0.006	0.018				
TURN-ON SETTLING TIME	To ±0.1% of Final Value		5			5			5		μs
QUIESCENT CURRENT	No Load		1.2	1.4		1.2	1.4		1.2	1.4	mA
LOAD CURRENT		10	21		10	21		10	21		mA
SINK CURRENT		-5	-10		*	*		*	*		mA
SHORT-CIRCUIT CURRENT	V <sub>O</sub> = 0		30			30			30		mA
POWER DISSIPATION			18			18			18		mW
TEMPERATURE RANGE Specification REF01A, B, C REF01R, S		-40		+85	*		*	*		*	°C
		-55		+125	*		*				°C

NOTES: (1)  $\Delta V_{OT}$  is defined as the absolute difference between the maximum output and the minimum output voltage over the specified temperature range expressed as a percentage of 10V:  $\Delta V_{O} = \frac{|V_{MAX} - V_{MIN}|}{10V} \times 100\%$  (2)  $\Delta V_{OT}$  specification applies trimmed to +10.000V or untrimmed. (3) TCV<sub>O</sub> is defined as  $\Delta V_{OT}$  divided

by the temperature range. (4) Line and load regulation specifications include the effect of self heating. (5) Sample tested. (6) 10kΩ potentiometer connected between V<sub>O</sub> and ground with wiper connected to trim pin. See Figure 3.

## ORDERING INFORMATION

MODEL	V <sub>OUT</sub> AT 25°C	MAX DRIFT (ppm/°C)	TEMPERATURE	PACKAGE
REF01AG	10V±30mV	±25	-40°C to +85°C	8-Pin Ceramic DIP
REF01AU	10V±30mV	±25	-40°C to +85°C	8-Pin SOIC
REF01BU	10V±25mV	±15	-40°C to +85°C	8-Pin SOIC
REF01AP	10V±30mV	±25	-40°C to +85°C	8-Pin Plastic DIP
REF01BG	10V±25mV	±15	-40°C to +85°C	8-Pin Ceramic DIP
REF01BP	10V±25mV	±15	-40°C to +85°C	8-Pin Plastic DIP
REF01AM	10V±30mV	±25	-40°C to +85°C	Metal TO-99
REF01BM	10V±25mV	±15	-40°C to +85°C	Metal TO-99
REF01CM	10V±20mV	±8.5	-40°C to +85°C	Metal TO-99
REF01RM	10V±30mV	±20	-55°C to +125°C	Metal TO-99
REF01SM	10V±25mV	±10	-55°C to +125°C	Metal TO-99

## DICE INFORMATION

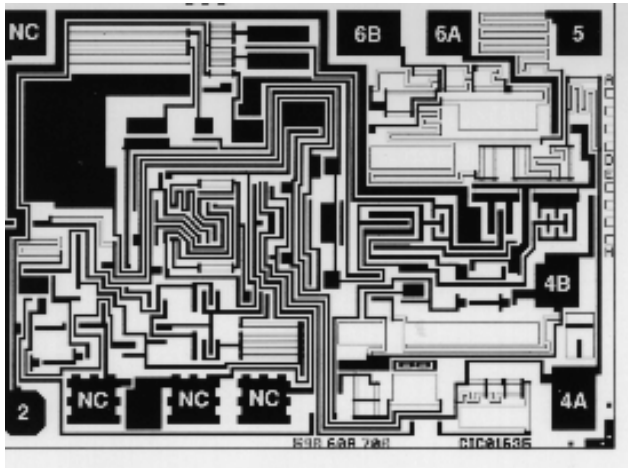

REF01 DIE TOPOGRAPHY

PAD	FUNCTION	PAD	FUNCTION
2	V <sub>IN</sub>	4B	GND
3A	NC	5	Trim
3B	NC	6A	V <sub>OUT</sub>
3C	NC	6B	V <sub>OUT</sub> (Sense)
4A	GND		

**Substrate Bias:** Common, pad 4B.

**NOTE:** Both common pads must be connected and both V<sub>OUT</sub> pads must be tied together.

## MECHANICAL INFORMATION

	MILS (0.001")	MILLIMETERS
Die Size	55 x 75	1.40 x 1.91 ±13
Die Thickness	20 ±3	0.51 ±0.08
Min. Pad Size	5 x 5	0.10 x 0.10
Backing	Gold	

The information provided herein is believed to be reliable; however, BURR-BROWN assumes no responsibility for inaccuracies or omissions. BURR-BROWN assumes no responsibility for the use of this information, and all use of such information shall be entirely at the user's own risk. Prices and specifications are subject to change without notice. No patent rights or licenses to any of the circuits described herein are implied or granted to any third party. BURR-BROWN does not authorize or warrant any BURR-BROWN product for use in life support devices and/or systems.

## ABSOLUTE MAXIMUM RATINGS<sup>(1)</sup>

Input Voltage .....	+40V
Operating Temperature	
G, P, U .....	-40°C to +85°C
M .....	-55°C to +125°C
Storage Temperature Range	
G, P, U .....	-65°C to +125°
M .....	-65°C to +150°
Output Short Circuit Duration (to Ground or $V_{IN}$ ) .....	Indefinite
Junction Temperature .....	-65°C to +150°
$\theta_{JA}$ P,G .....	120°C/W
U .....	80°C/W
M .....	150°C/W
Lead Temperature (soldering, 60s) .....	+300°C

## PACKAGE INFORMATION<sup>(1)</sup>

MODEL	PACKAGE	PACKAGE DRAWING NUMBER
REF01AG	8-Pin Ceramic DIP	161
REF01AU	8-Pin SOIC	182
REF01BU	8-Pin SOIC	182
REF01AP	8-Pin Plastic DIP	006
REF01BG	8-Pin Ceramic DIP	161
REF01BP	8-Pin Plastic DIP	006
REF01AM	Metal TO-99	001
REF01BM	Metal TO-99	001
REF01CM	Metal TO-99	001
REF01RM	Metal TO-99	001
REF01SM	Metal TO-99	001

NOTE: (1) For detailed drawing and dimension table, please see end of data sheet, or Appendix D of Burr-Brown IC Data Book.

## PIN CONFIGURATIONS

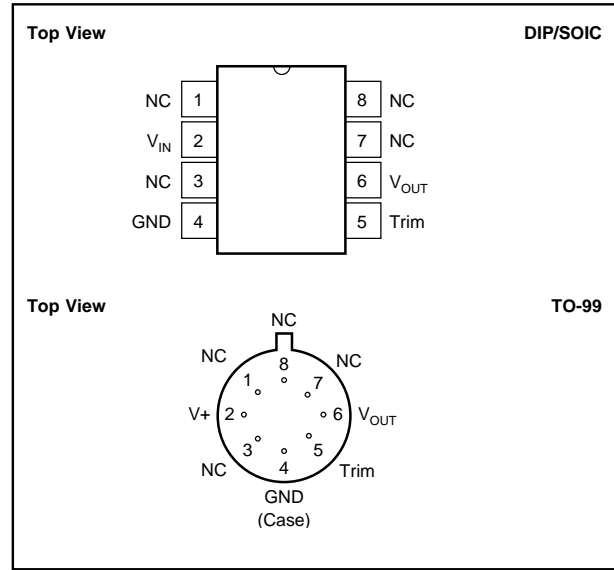

## TYPICAL PERFORMANCE CURVES

$T_A = +25^\circ\text{C}$  and  $V_S = +15\text{V}$  power supply unless otherwise noted.

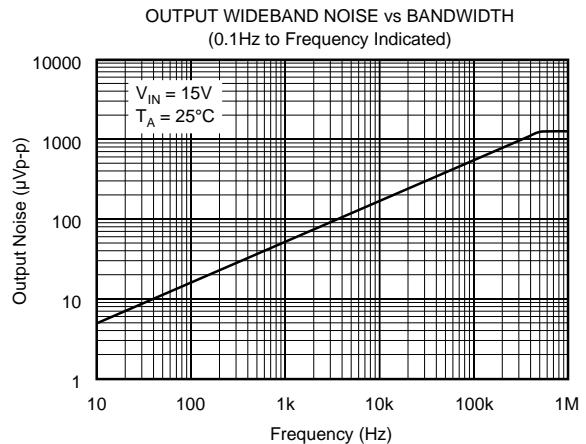
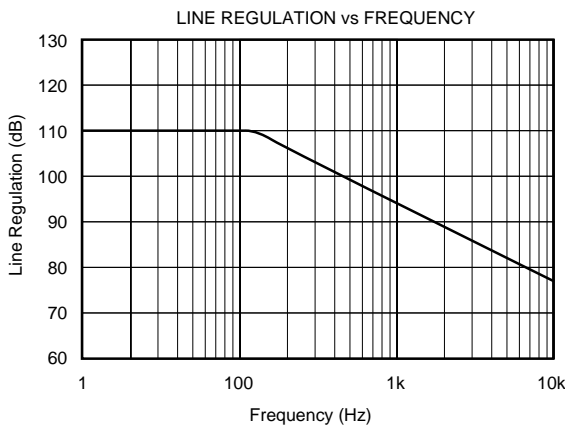

# TYPICAL PERFORMANCE CURVES (CONT)

$T_A = +25^\circ\text{C}$  and  $V_S = +15\text{V}$  power supply unless otherwise noted.

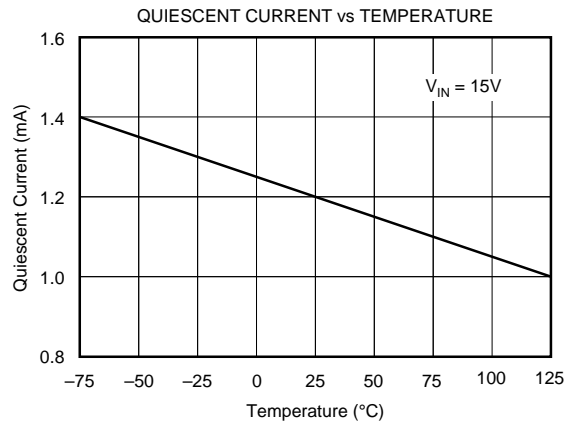
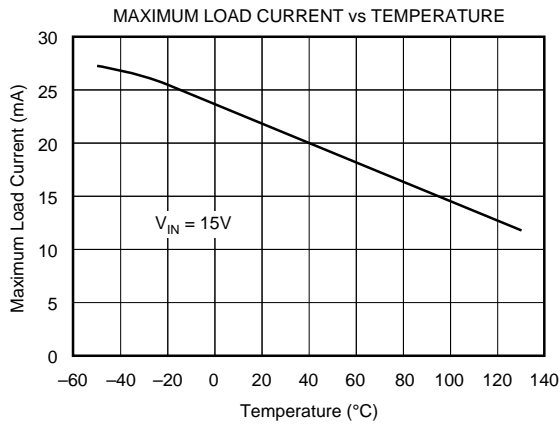
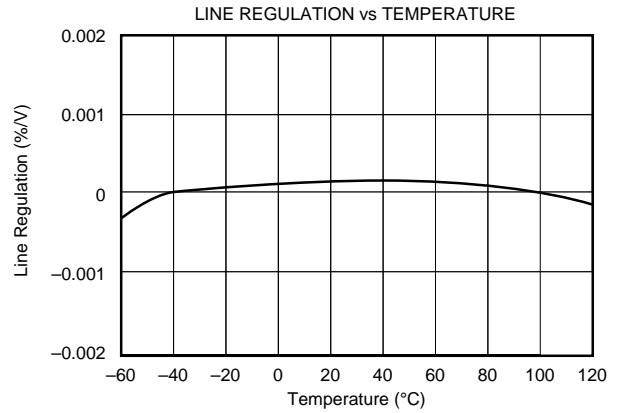
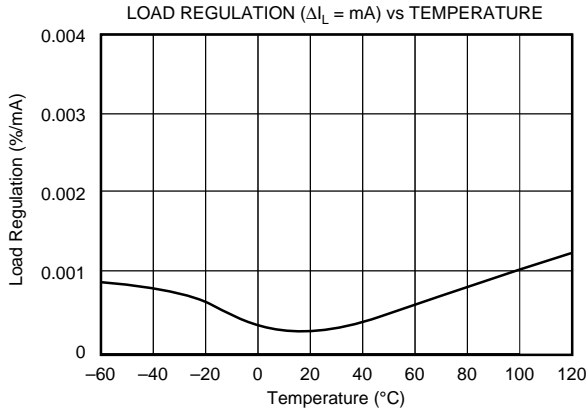
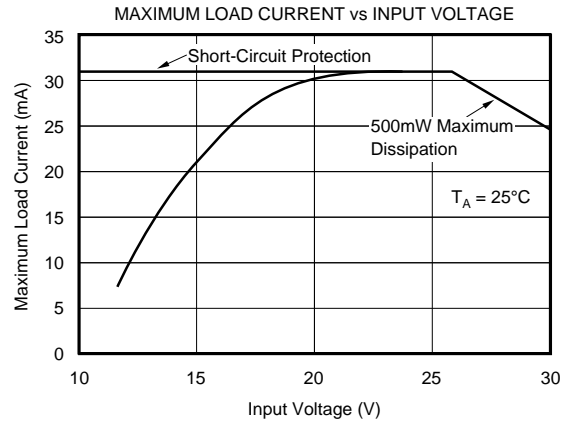
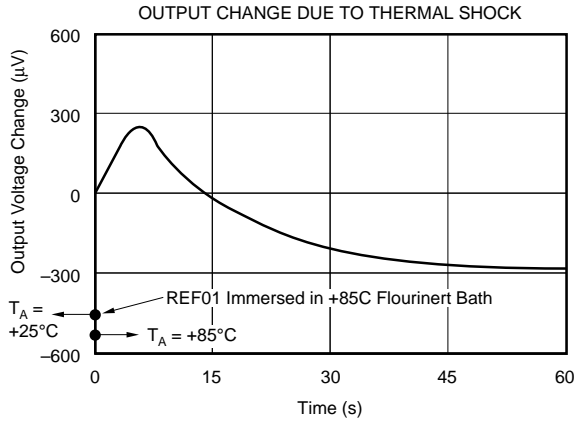

## OUTPUT ADJUSTMENT

The REF01 trim terminal can be used to adjust the voltage over a 10V  $\pm 300\text{mV}$  range. This feature allows the system designer to trim system errors by setting the reference to a voltage other than 10V, including 10.240V for binary applications (see circuit on the first page).

Adjustment of the output does not significantly affect the temperature performance of the device. The temperature coefficient change is approximately 0.5ppm/ $^{\circ}\text{C}$  for 100mV of output adjustment.

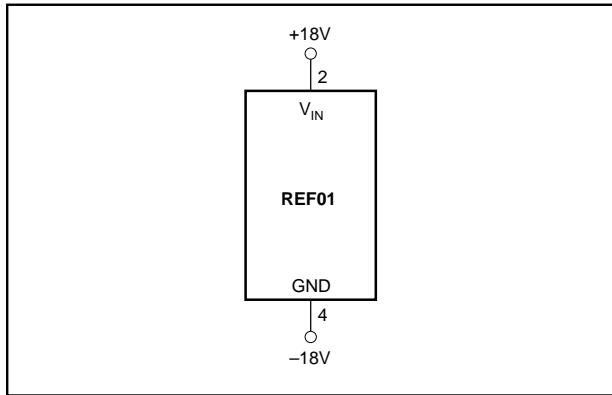

FIGURE 1. Burn-In Circuit.

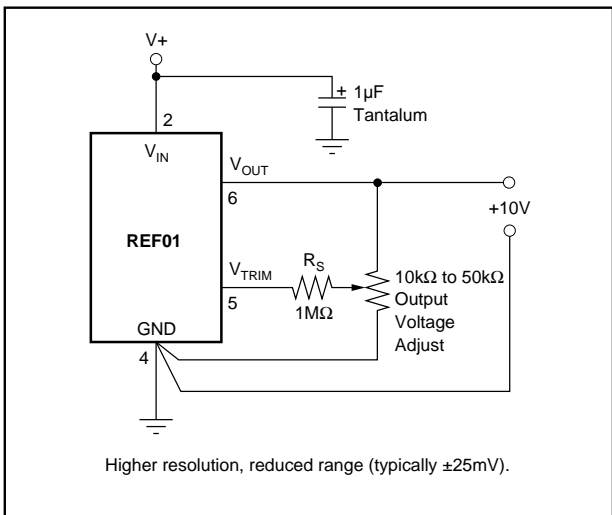

FIGURE 2. High Resolution Output Adjustment.

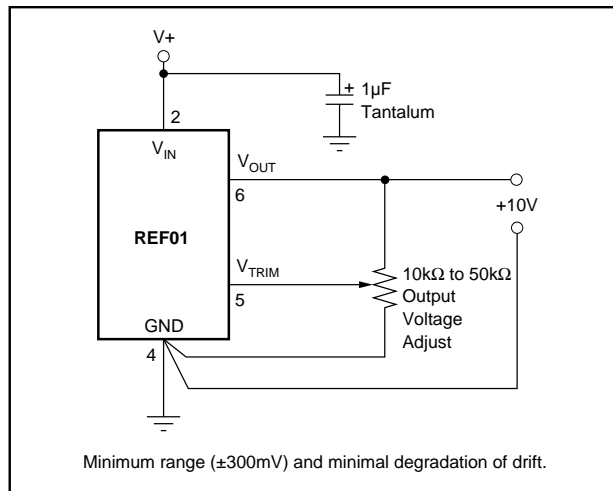

FIGURE 3. Optional Output Voltage Adjustment.

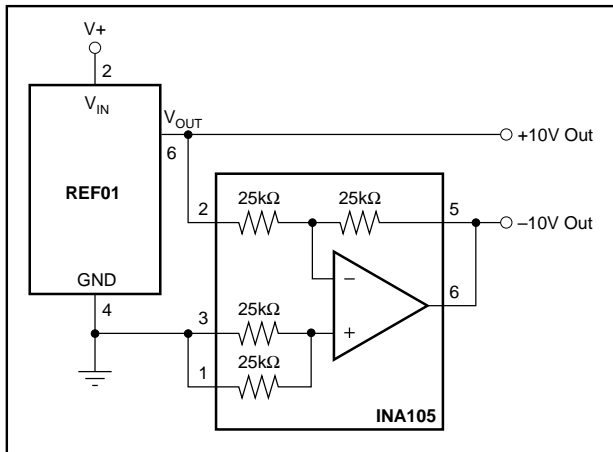

FIGURE 4.  $\pm 10\text{V}$  Reference.

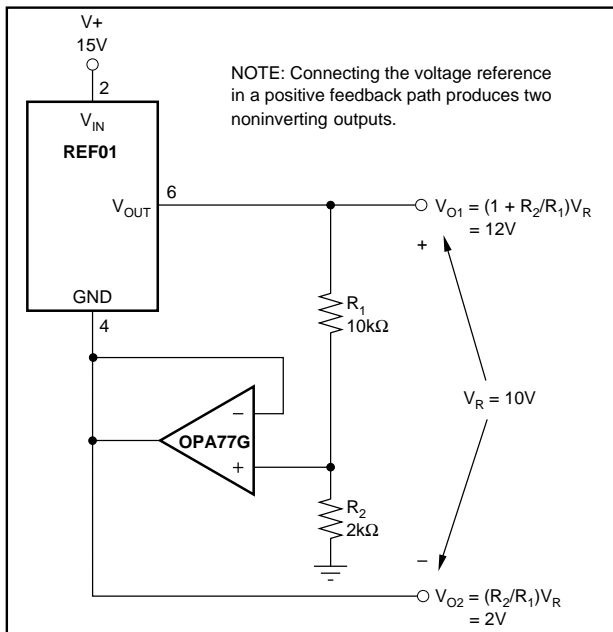

FIGURE 5. +2V and +12V Reference.



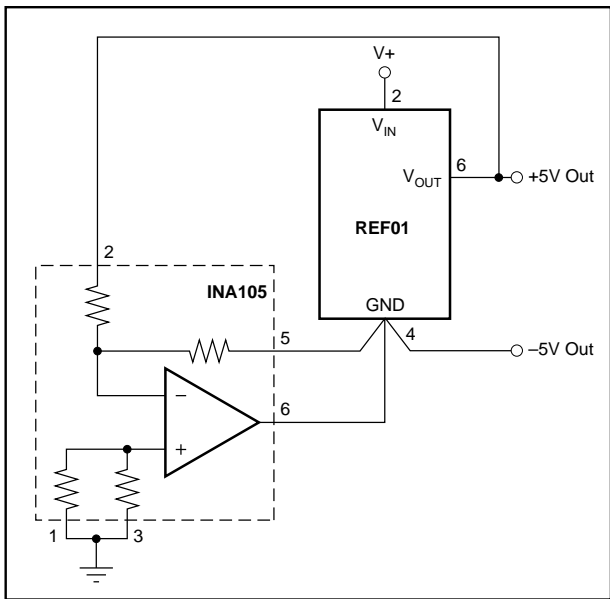

FIGURE 10. ±5V Reference.

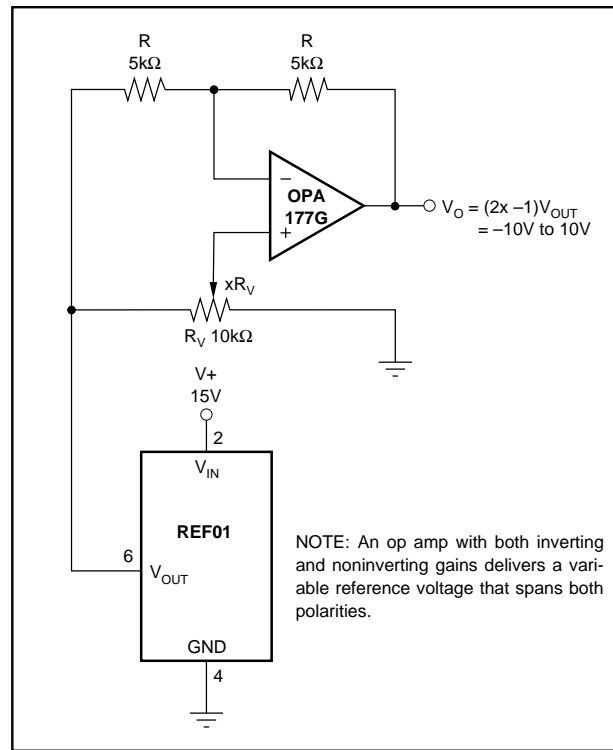

FIGURE 12. Bipolar-Output Adjustable Reference.

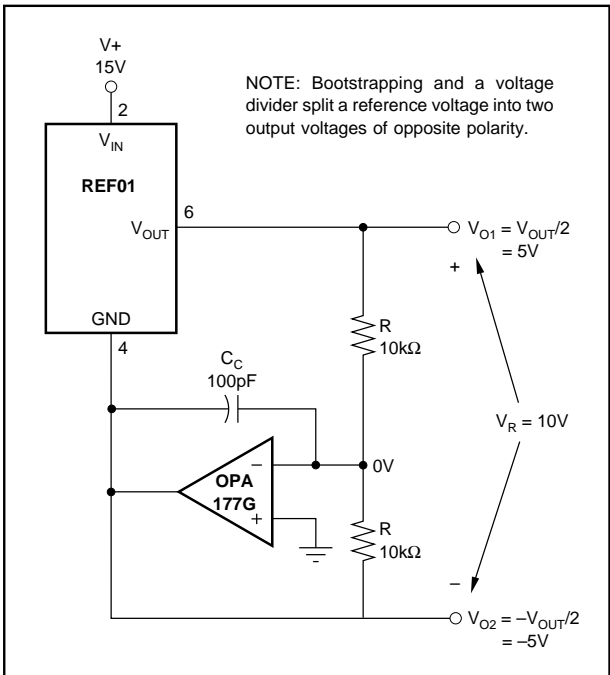
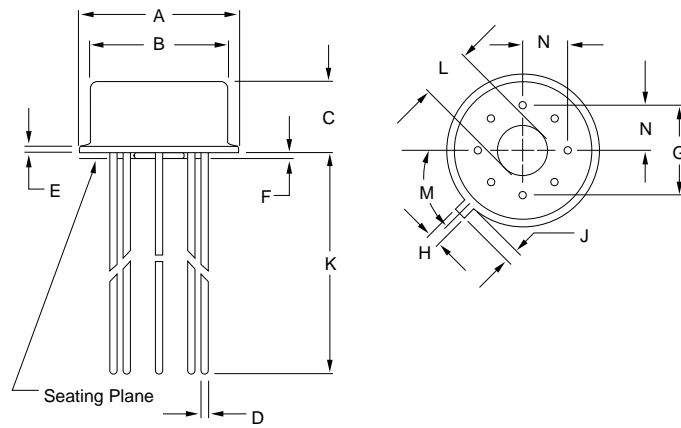

FIGURE 11. ±5V Reference.



## MECHANICALS

Package Number 001 — Metal TO-99



DIM	INCHES		MILLIMETERS	
	MIN	MAX	MIN	MAX
A	.335	.370	8.51	9.40
B	.305	.335	7.75	8.51
C	.165	.185	4.19	4.70
D	.016	.021	0.41	0.53
E	.010	.040	0.25	1.02
F	.010	.040	0.25	1.02
G	.200 BASIC		5.08 BASIC	
H	.028	.034	0.71	0.86
J	.029	.045	0.74	1.14
K	.500	—	12.7	—
L	.110	.160	2.79	4.06
M	45° BASIC		45° BASIC	
N	.095	.105	2.41	2.67

NOTE: Leads in true position within 0.01" (0.25mm) R at MMC at seating plane. Tab is pin 8.

Package Number 006 — 8-Pin Plastic Single-Wide DIP

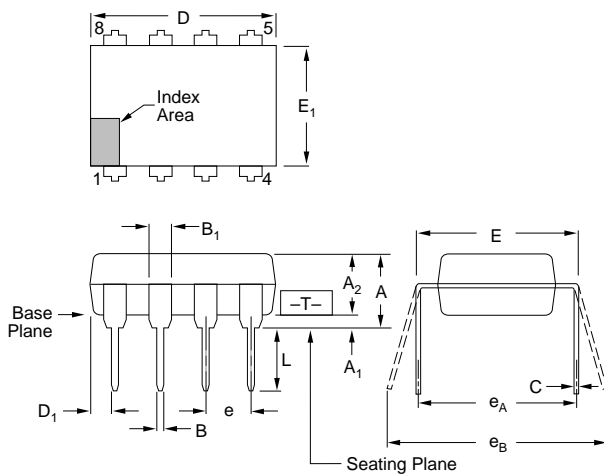

DIM	INCHES		MILLIMETERS	
	MIN	MAX	MIN	MAX
A <sup>(3)</sup>	—	.210	—	5.33
A <sub>1</sub> <sup>(3)</sup>	.015	—	0.38	—
A <sub>2</sub>	.115	.195	2.92	4.95
B	.014	.022	0.36	0.56
B <sub>1</sub>	.045	.070	1.14	1.78
C	.008	.015	0.20	0.38
D <sup>(4)</sup>	.348	.430	8.84	10.92
D <sub>1</sub>	.005	—	0.13	—
E <sup>(5)</sup>	.300	.325	7.62	8.26
E <sub>1</sub> <sup>(4)</sup>	.240	.280	6.10	7.11
e	.100 BASIC		2.54 BASIC	
eA <sup>(5)</sup>	.300 BASIC		7.63 BASIC	
eB <sup>(6)</sup>	—	.430	—	10.92
L <sup>(8)</sup>	.115	.160	2.92	4.06
N <sup>(7)</sup>	8		8	

(1) Controlling dimension: Inch. In case of conflict between the English and metric dimensions, the inch dimensions control.

(2) Dimensioning and tolerancing per ANSI Y14.5M-1982.

(3) Dimensions A, A<sub>1</sub>, and L are measured with the package seated in JEDEC seating plane gauge GS-3.

(4) D and E<sub>1</sub> dimensions for plastic packages do not include mold flash or protrusions. Mold flash or protrusions shall not exceed .010 inch (0.25mm).

(5) E and eA measured with the leads constrained to be perpendicular to plane T.

(6) eB is measured at the lead tips with the leads unconstrained.

(7) N is the maximum number of terminal positions.

(8) Corner leads (1, 4, 5, and 8) may be configured as shown in Figure 2.

(9) For automatic insertion, any raised irregularity on the top surface (step, mesa, etc.) shall be symmetrical about the lateral and longitudinal package center-lines.

Package Number 182 — 8-Pin SO-8 Surface Mount

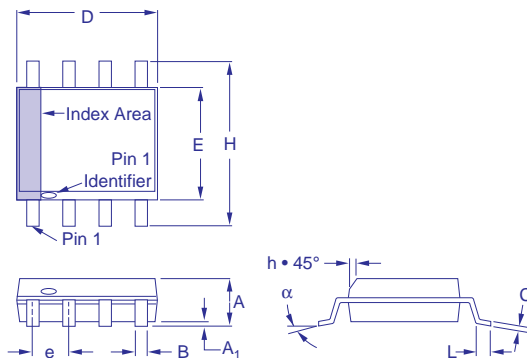

DIM	INCHES		MILLIMETERS	
	MIN	MAX	MIN	MAX
A	.054	.068	1.37	1.73
A <sub>1</sub>	.004	.009	0.10	0.23
B	.014	.019	0.36	0.48
C	.008	.0098	0.20	0.25
D	.189	.196	4.80	4.98
E	.150	.157	3.81	3.99
e	.050 BASIC		1.27 BASIC	
H	.229	.244	5.82	6.20
h	.010	.019	0.25	0.48
L	.016	.050	0.41	1.27
N	8		8	
α	0° 8°		0° 8°	

### NOTES:

- Dimensioning and tolerancing per ANSI Y14.5M-1982.
- "D" and "E" are reference datums and do not include mold flash or protrusions. Mold flash or protrusions shall not exceed 0.15mm (.086 in.)
- The chamfer on the body is optional. If it is not present, a visual index feature must be located within the cross-hatched area.
- "L" is the length of the terminal for soldering to a substrate.
- "N" is the number of terminal positions.

## MECHANICALS (CONT)

Package Number 161 — 8-Pin Ceramic

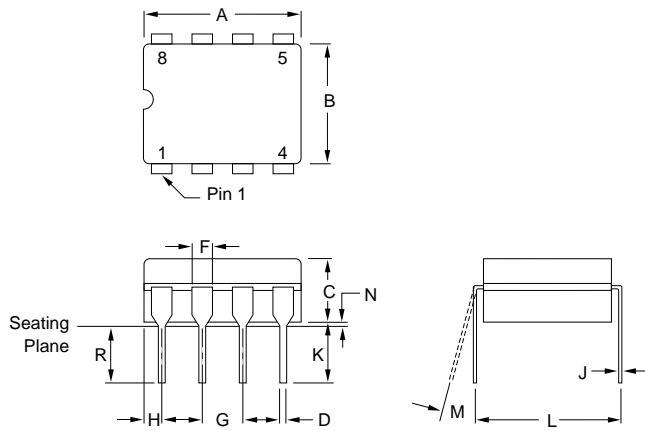

DIM	INCHES		MILLIMETERS	
	MIN	MAX	MIN	MAX
A	.375	.405	9.53	10.28
B	.280	.295	7.11	7.50
C	.140	.170	3.56	4.32
D	.015	.021	0.38	0.53
F	.045	.060	1.14	1.52
G	.100 BASIC		2.54 BASIC	
H	—	.098	—	2.49
J	.008	.012	0.20	0.30
K	.150	—	3.80	—
L	.290	.320	7.37	8.13
M	0°	15°	0°	15°
N	.009	.060	0.23	1.52
R	.125	.175	3.18	4.45

NOTE: Leads in true position within 0.01" (0.25mm) R at MMC at seating plane. Pin numbers shown for reference only. Numbers may not be marked on the package.