

Structure Silicon Monolithic Integrated Circuit
 Product Series 1ch Sensorless Spindle Motor Driver for MD
 Type BA6966FV
 Features

- Soft-switching/sensorless driving method
- VM voltage variable control method
- Deals with double speed operation
- Startup/Brake/Standby function
- FG signal output function
- Thermal shutdown circuit
- Small package SSOP-B20

○Absolute maximum ratings (Ta=25°C)

Parameter	Symbol	Limit	Unit
Power supply voltage	Vcc	7	V
Input voltage	VIN	0~VCC	V
Output current	I _{OMAX}	*1000	mA
Power dissipation	Pd	**800	mW
Operating temperature range	Topr	-25~+75	°C
Storage temperature range	Tstg	-55~+150	°C
Junction temperature	Tjmax	+150	°C

* Must not exceed Pd or ASO, Tjmax=150°C.

** Reduced by 6.4mW/°C over Ta=25°C, when mounted on a glass epoxy board (70mm×70mm×1.6mm).

○Operating conditions (Ta=-25~+75°C)

Parameter	Symbol	Range	Unit
Operating power supply voltage range	Vcc	2.4~6.5	V
	VM	0~Vcc	V

This product described in this specification is not judged whether it applies to COCOM regulations.

Please confirm in case of export.

This product is not designed for protection against radioactive rays.

○Electrical characteristics

(Unless otherwise specified, Ta=25°C, VCC=2.7V, VM=0.3V)

Parameter	Symbol	Limit			Unit	Conditions
		Min.	Typ.	Max.		
Circuit current	ICCS	—	20	40	μA	STBY=L
	ICC	—	4	5.5	mA	STBY=H IM=20mA
Output saturation voltage H1	VOH1	—	0.85	1	V	VM=2.7V Io=400mA
Output saturation voltage H2	VOH2	—	0.2	0.35	V	VM=VCC-1V Io=400mA
Output saturation voltage L	VOL	—	0.25	0.35	V	Io=400mA
~Rotor position detection comparator~						
Input offset voltage	VCO	-10	—	+10	mV	
In-phase input voltage range	VCD	0	—	VCC-1.5	V	
~Standby pin~						
Input current	IST	—	70	120	μA	STBY=VCC
Input high level voltage	VSTH	VCC-0.5	—	VCC	V	
Input low level voltage	VSTL	—	—	0.3	V	
~Brake comparator~						
Input current	IBR	—	—	2.0	μA	BRK=VCC
Input offset voltage	VBO	-15	—	+15	mV	
In-phase input voltage range	VBD	0	—	VCC-1.5	V	
~CST pin~						
Charge current	ICTO	-1.3	-2.5	-3.7	μA	CST=1V
Discharge current	ICTI	2.6	5.0	7.4	mA	CST=1V
Clamp H voltage	VCTH	0.6	1.35	2.1	V	
Clamp L voltage	VCTL	0.13	0.3	0.57	V	
~CSL pin~						
Charge current	ICLO	-4	-8.5	-13	μA	
Discharge current	ICLI	2.6	5.0	7.4	μA	
Clamp H voltage	VCLH	VCC-0.25	VCC-0.05	—	V	
Clamp L voltage	VCLL	VCLH-0.75	VCLH-0.6	VCLH-0.45	V	
~RIB pin~						
Offset voltage	VRO	—	15.5	19	mV	
~FG pin~						
Output L voltage	VOLF	—	0.1	0.25	V	
Pull-up resistance	RBF	10	20	30	kΩ	

©This product is not designed for protection against radioactive rays.

○Package outlines

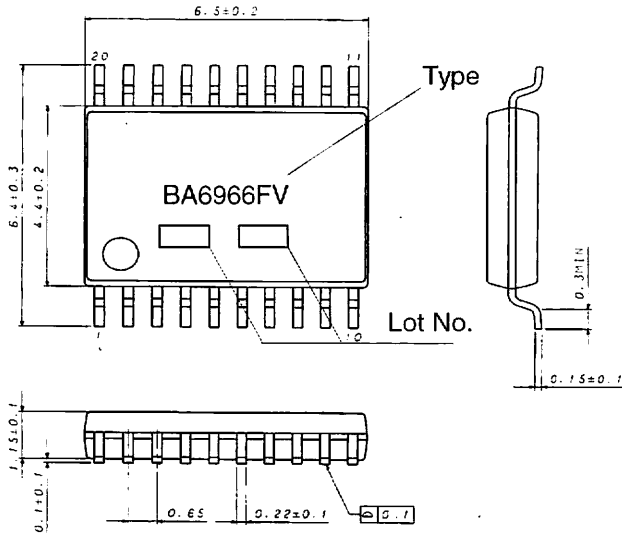

SSOP-B20 outlines (Unit : mm)

○Block diagram

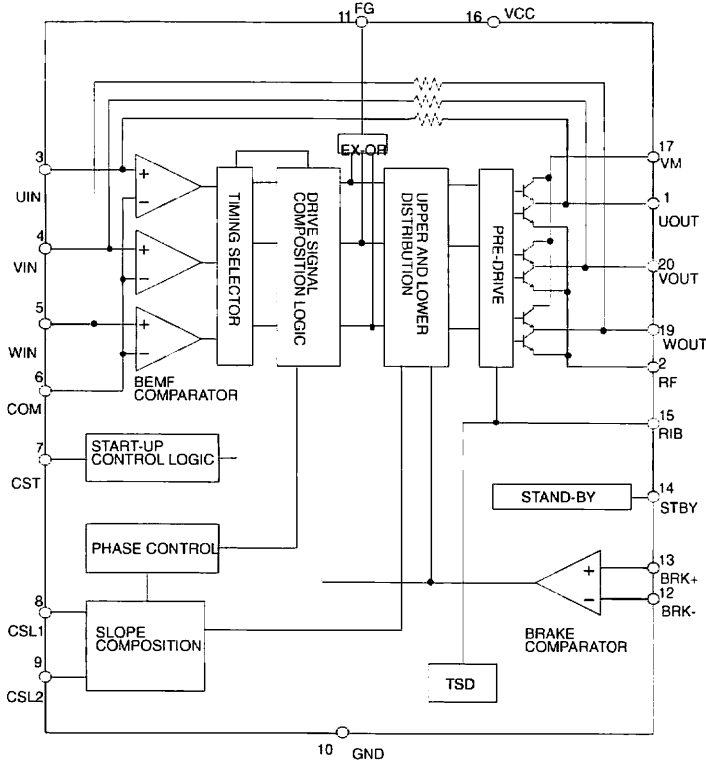

○Pin No./Pin name

No	Pin name	Function
1	UOUT	Phase U coil output pin
2	RF	Output current detection pin (Power block GND)
3	UIN	Rotor position detection comparator input pin
4	VIN	
5	WIN	
6	COM	Motor coil neutral point input pin
7	CST	Startup oscillation capacitor connection pin
8	CSL1	Slope capacitor connection pin
9	CSL2	
10	GND	Signal block GND
11	FG	FG output pin
12	BRK-	Brake comparator input pin
13	BRK+	
14	STBY	Standby pin
15	RIB	Output Tr. base current setting resistor connection pin
16	VCC	Signal block power supply pin
17	VM	Motor output block power supply pin
18	N.C.	
19	WOUT	Phase W coil output pin
20	VOUT	Phase V coil output pin

○Notes on the use

- (1) Absolute maximum ratings
If the input voltage or the operating temperature range exceeds absolute maximum ratings, IC may be damaged. No destruction mode (e.g., short-circuiting or open) can be specified in that case. If such special mode as will exceed absolute maximum ratings is assumed, take the physical safety measures, such as a fuse.
- (2) Power supply lines
The regenerated current by BEMF of the motor will return. Therefore, take measures, such as the insertion of a capacitor between the power supply and GND as the pass of the regenerated current. Determine the capacitance in full consideration of all the characteristics of the electrolytic capacitor, because the electrolytic capacitor may loose some capacitance at low temperatures.
- (3) Ground potential
Ensure a minimum GND pin potential in all operating conditions.
- (4) Design for heat
Use the design for heat that allows for a sufficient margin in light of the power dissipation (Pd) in actual using conditions.
- (5) Operation in strong magnetic field
Use caution when using the IC in the strong magnetic field as doing so may cause the IC to malfunction.
- (6) ASO
When using the IC, make settings so that the output transistors for the motor will not be used under conditions in excess of the absolute maximum ratings and ASO.
- (7) Thermal shutdown circuit
This IC incorporates thermal shutdown circuit(TSD circuit).
When the chip temperature becomes the one shown in below, TSD circuit operates and makes the coil output to motor open. It is designed to shut the IC off from runaway thermal operation. It is not designed to protect the IC or guarantee its operation. Do not continue to use the IC after operating this circuit or use the IC in an environment where the operation of this circuit is assumed.

TSD ON temperature[°C] (typ.)	Hysteresis temperature [°C] (typ.)
165	20

- (8) Ground wiring pattern
When having both small signal and large current GND, it is recommended to isolate the two GND patterns, placing a single ground point at the application's reference point so that the pattern wiring resistance and voltage variations caused by large currents do not cause voltage variations of the small signal GND. Be careful not to change the GND wiring pattern of any external parts, either.

Notes

- No technical content pages of this document may be reproduced in any form or transmitted by any means without prior permission of ROHM CO.,LTD.
- The contents described herein are subject to change without notice. The specifications for the product described in this document are for reference only. Upon actual use, therefore, please request that specifications to be separately delivered.
- Application circuit diagrams and circuit constants contained herein are shown as examples of standard use and operation. Please pay careful attention to the peripheral conditions when designing circuits and deciding upon circuit constants in the set.
- Any data, including, but not limited to application circuit diagrams information, described herein are intended only as illustrations of such devices and not as the specifications for such devices. ROHM CO.,LTD. disclaims any warranty that any use of such devices shall be free from infringement of any third party's intellectual property rights or other proprietary rights, and further, assumes no liability of whatsoever nature in the event of any such infringement, or arising from or connected with or related to the use of such devices.
- Upon the sale of any such devices, other than for buyer's right to use such devices itself, resell or otherwise dispose of the same, no express or implied right or license to practice or commercially exploit any intellectual property rights or other proprietary rights owned or controlled by
- ROHM CO., LTD. is granted to any such buyer.
- Products listed in this document are no antiradiation design.

The products listed in this document are designed to be used with ordinary electronic equipment or devices (such as audio visual equipment, office-automation equipment, communications devices, electrical appliances and electronic toys).

Should you intend to use these products with equipment or devices which require an extremely high level of reliability and the malfunction of which would directly endanger human life (such as medical instruments, transportation equipment, aerospace machinery, nuclear-reactor controllers, fuel controllers and other safety devices), please be sure to consult with our sales representative in advance.

About Export Control Order in Japan

Products described herein are the objects of controlled goods in Annex 1 (Item 16) of Export Trade Control Order in Japan.

In case of export from Japan, please confirm if it applies to "objective" criteria or an "informed" (by MITI clause) on the basis of "catch all controls for Non-Proliferation of Weapons of Mass Destruction.

Thank you for your accessing to ROHM product informations.
More detail product informations and catalogs are available,
please contact your nearest sales office.

Please contact our sales offices for details ;

U.S.A / San Diego	TEL : +1(858)625-3630	FAX : +1(858)625-3670
Atlanta	TEL : +1(770)754-5972	FAX : +1(770)754-0691
Dallas	TEL : +1(972)312-8818	FAX : +1(972)312-0330
Germany / Dusseldorf	TEL : +49(2154)9210	FAX : +49(2154)921400
United Kingdom / London	TEL : +44(1)908-282-666	FAX : +44(1)908-282-528
France / Paris	TEL : +33(0)1 56 97 30 60	FAX : +33(0) 1 56 97 30 80
China / Hong Kong	TEL : +852(2)740-6262	FAX : +852(2)375-8971
Shanghai	TEL : +86(21)6279-2727	FAX : +86(21)6247-2066
Dilian	TEL : +86(411)8230-8549	FAX : +86(411)8230-8537
Beijing	TEL : +86(10)8525-2483	FAX : +86(10)8525-2489
Taiwan / Taipei	TEL : +866(2)2500-6956	FAX : +866(2)2503-2869
Korea / Seoul	TEL : +82(2)8182-700	FAX : +82(2)8182-715
Singapore	TEL : +65-6332-2322	FAX : +65-6332-5662
Malaysia / Kuala Lumpur	TEL : +60(3)7958-8355	FAX : +60(3)7958-8377
Philippines / Manila	TEL : +63(2)807-6872	FAX : +63(2)809-1422
Thailand / Bangkok	TEL : +66(2)254-4890	FAX : +66(2)256-6334

Japan /
(Internal Sales)

Tokyo	2-1-1, Yaesu, Chuo-ku, Tokyo 104-0082	TEL : +81(3)5203-0321	FAX : +81(3)5203-0300
Yokohama	2-4-8, Shin Yokohama, Kohoku-ku, Yokohama, Kanagawa 222-8575	TEL : +81(45)476-2131	FAX : +81(45)476-2128
Nagoya	Dainagayo Building 9F 3-28-12, Meieki, Nakamura-ku, Nagoya, Aichi 450-0002	TEL : +81(52)581-8521	FAX : +81(52)561-2173
Kyoto	579-32 Higashi Shiokouji-cho, Karasuma Nishi-iru, Shiokoujidori, Shimogyo-ku, Kyoto 600-8216	TEL : +81(75)311-2121	FAX : +81(75)314-6559

(Contact address for overseas customers in Japan)

Yokohama	TEL : +81(45)476-9270	FAX : +81(045)476-9271
----------	-----------------------	------------------------