

AN8480NSB

3-phase full-wave motor driver IC

Overview

The AN8480NSB is a 3-phase full-wave motor driver IC with a reverse rotation brake/short brake changeover function, incorporating a thermal protection circuit with its protection monitor pin.

Features

- 3-phase full-wave and snubberless
- FG output
- Current limit
- Reverse rotation prevention
- Thermal protection circuit built-in (with thermal protection monitor pin)

Applications

- Various types of optical disk drive

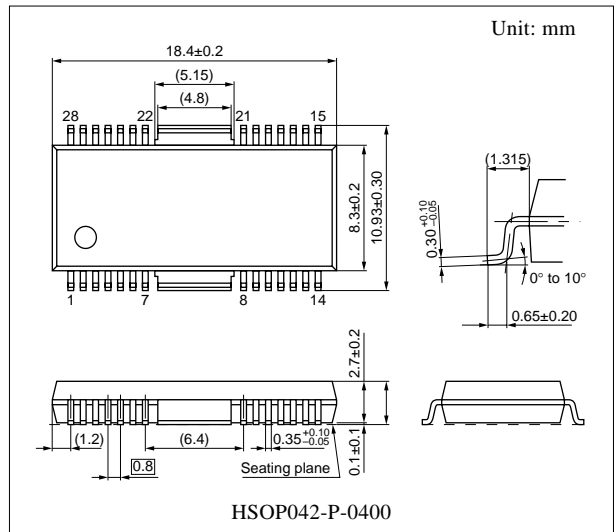

Block Diagram

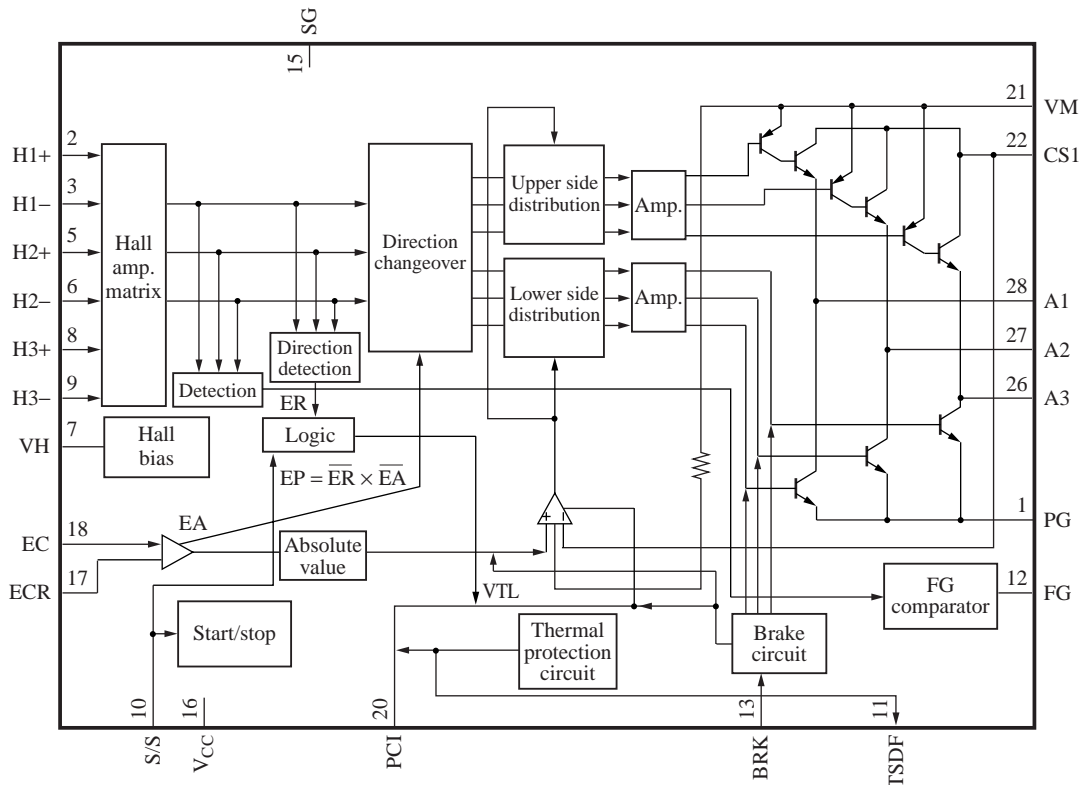

■ Pin Descriptions

Pin No.	Symbol	Description	Pin No.	Symbol	Description
1	PG	Power GND pin	15	SG	Signal GND pin
2	H1+	Hall element-1 positive input pin	16	V _{CC}	Supply voltage pin
3	H1-	Hall element-1 negative input pin	17	ECR	Torque command reference input pin
4	N.C.	N.C.	18	EC	Torque command input pin
5	H2+	Hall element-2 positive input pin	19	N.C.	N.C.
6	H2-	Hall element-2 negative input pin	20	PCI	Current feedback phase compensation pin
7	VH	Hall bias pin	21	VM	Motor supply voltage pin
8	H3+	Hall element-3 positive input pin	22	CS	Current det. pin 1
9	H3-	Hall element-3 negative input pin	23	N.C.	N.C.
10	SS	Start/stop changeover pin	24	N.C.	N.C.
11	TFLG	Thermal protection monitor pin	25	N.C.	N.C.
12	FG	FG signal output pin	26	A3	Drive output 3
13	BRK	Brake mode setting pin	27	A2	Drive output 2
14	N.C.	N.C.	28	A1	Drive output 1

■ Absolute Maximum Ratings

Parameter	Symbol	Rating	Unit
Supply voltage	V _{CC}	7.0	V
	V _M	14.4	
Control signal input voltage *4	V _(n)	0 to V _{CC}	V
Supply current	I _{CC}	30	mA
Output current *3	I _{O(n)}	±1 200	mA
Hall bias current	I _{HB}	50	mA
Power dissipation *2	P _D	667	mW
Operating ambient temperature *1	T _{opr}	-20 to +70	°C
Storage temperature *1	T _{stg}	-55 to +150	°C

Note) Do not apply external currents or voltages to any pins not specifically mentioned.

For circuit currents, '+' denotes current flowing into the IC, and '-' denotes current flowing out of the IC.

*1: Except for the operating ambient temperature and storage temperature, all ratings are for T_a = 25°C.

*2: For 70°C and IC alone.

*3: n = 1, 22, 26, 27, 28

*4: n = 2, 3, 5, 6, 8, 9, 10, 13, 17, 18

■ Recommended Operating Range

Parameter	Symbol	Range	Unit
Supply voltage	V _{CC}	4.25 to 5.5	V
	V _M	4.5 to 14	

■ Electrical Characteristics at $T_a = 25^\circ\text{C}$

Parameter	Symbol	Conditions	Min	Typ	Max	Unit
Overall						
Circuit current 1	I_{CC1}	$V_{CC} = 5\text{ V}$ in power save mode	—	0	0.1	mA
Circuit current 2	I_{CC2}	$V_{CC} = 5\text{ V}$, $I_O = 0\text{ mA}$	1	8	16	mA
Start/stop						
Start voltage	V_{START}	Voltage with which a circuit operates at $V_{CC} = 5\text{ V}$ and $L \rightarrow H$	2.7	—	—	V
Stop voltage	V_{STOP}	Voltage with which a circuit becomes off at $V_{CC} = 5\text{ V}$ and $H \rightarrow L$	—	—	0.7	V
Medium voltage	V_{MED}	Voltage with which V_{PC1} becomes low at $V_{CC} = 5\text{ V}$ and $EC = 0\text{ V}$	1.55	—	1.75	V
Hall bias						
Hall bias voltage	V_{HB}	$V_{CC} = 5\text{ V}$, $I_{HB} = 20\text{ mA}$	0.7	1.2	1.6	V
Hall amplifier						
Input bias current	I_{BH}	$V_{CC} = 5\text{ V}$	—	1	5	μA
In-phase input voltage range	V_{HBR}	$V_{CC} = 5\text{ V}$	1.5	—	4.0	V
Minimum input level	V_{INH}	$V_{CC} = 5\text{ V}$	60	—	—	mV[p-p]
Torque command						
In-phase input voltage range	EC	$V_{CC} = 5\text{ V}$	0.5	—	3.9	V
Offset voltage	EC_{OF}	$V_{CC} = 5\text{ V}$	-100	0	100	mV
Dead zone	EC_{DZ}	$V_{CC} = 5\text{ V}$	25	75	125	mV
Input current	EC_{IN}	$V_{CC} = 5\text{ V}$, $EC = ECR = 1.65\text{ V}$	-5	-1	—	μA
Input/output gain	A_{CS}	$V_{CC} = 5\text{ V}$, $R_{CS} = 0.5\ \Omega$	0.75	1.0	1.25	A/V
Output						
High-level output saturation voltage	V_{OH}	$V_{CC} = 5\text{ V}$, $I_O = -300\text{ mA}$	—	0.9	1.6	V
Low-level output saturation voltage	V_{OL}	$V_{CC} = 5\text{ V}$, $I_O = 300\text{ mA}$	—	0.2	0.6	V
Torque limit current	I_{TL}	$V_{CC} = 5\text{ V}$, $R_{CS} = 0.5\ \Omega$	400	500	600	mA
FG						
FG output high-level	FG_H	$V_{CC} = 5\text{ V}$, $I_{FG} = -0.01\text{ mA}$	3.0	—	V_{CC}	V
FG output low-level	FG_L	$V_{CC} = 5\text{ V}$, $I_{FG} = 0.01\text{ mA}$	—	—	0.5	V
In-phase input voltage range	V_{FGR}	$V_{CC} = 5\text{ V}$, Input D-range at H2+, H2-	1.5	—	3.0	V
FG hysteresis width	H_{FG}	$V_{CC} = 5\text{ V}$	1	10	20	mV
Brake circuit						
Short brake model level	V_{SBR}	$V_{CC} = 5\text{ V}$	—	—	1.0	V
Reverse rotation brake mode level	V_{RBR}	$V_{CC} = 5\text{ V}$	3.5	—	—	V
Short brake start level	V_{SBRL}	$V_{CC} = 5\text{ V}$, $ECR = 1.65\text{ V}$	1.65	1.74	—	V
Short brake current	I_{SBR}	$V_{CC} = 5\text{ V}$	12	35	—	mA

■ Electrical Characteristics at $T_a = 25^\circ\text{C}$ (continued)

• Design reference data

Note) The characteristics listed below are theoretical values based on the IC design and are not guaranteed.

Parameter	Symbol	Conditions	Min	Typ	Max	Unit
Thermal protection						
Thermal protection operating temperature	T_{SDON}	$V_{CC} = 5\text{ V}, \Delta EC = 100\text{ mV}$	—	160	—	$^\circ\text{C}$
Thermal protection hysteresis width	ΔT_{SD}	$V_{CC} = 5\text{ V}, \Delta EC = 100\text{ mV}$	—	45	—	$^\circ\text{C}$
Thermal protection flag						
Level at thermal protection = on	V_{TSDON}	$V_{CC} = 5\text{ V}$	—	—	0.5	V
Level at thermal protection = off	V_{TSDOFF}	$V_{CC} = 5\text{ V}$	3.0	—	—	V

■ Usage Notes

Prevent this IC from being line-to-ground fault. (To be concrete, do not short-circuit any of A1 (pin 28), A2 (pin 27) and A3 (pin 26) with VM pin (pin 21).)

■ Application Notes

- $P_D - T_a$ curves of HSOP042-P-0400

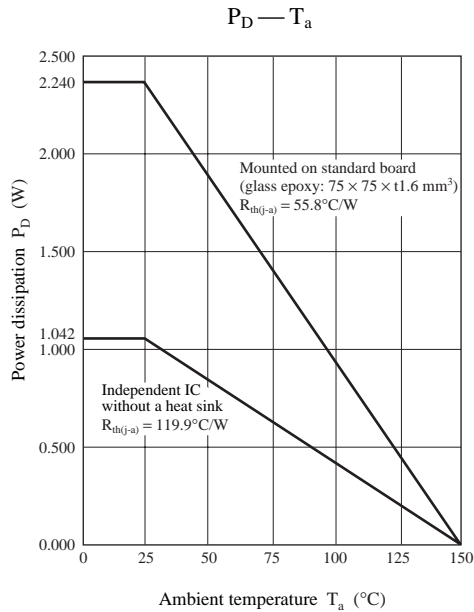

■ Application Notes (continued)

• Phase conditions between Hall input and output current

Phase of Hall pin			
	H1+	H2+	H3+
A	H	M	L
B	H	L	M
C	M	L	H
D	L	M	H
E	L	H	M
F	M	H	L

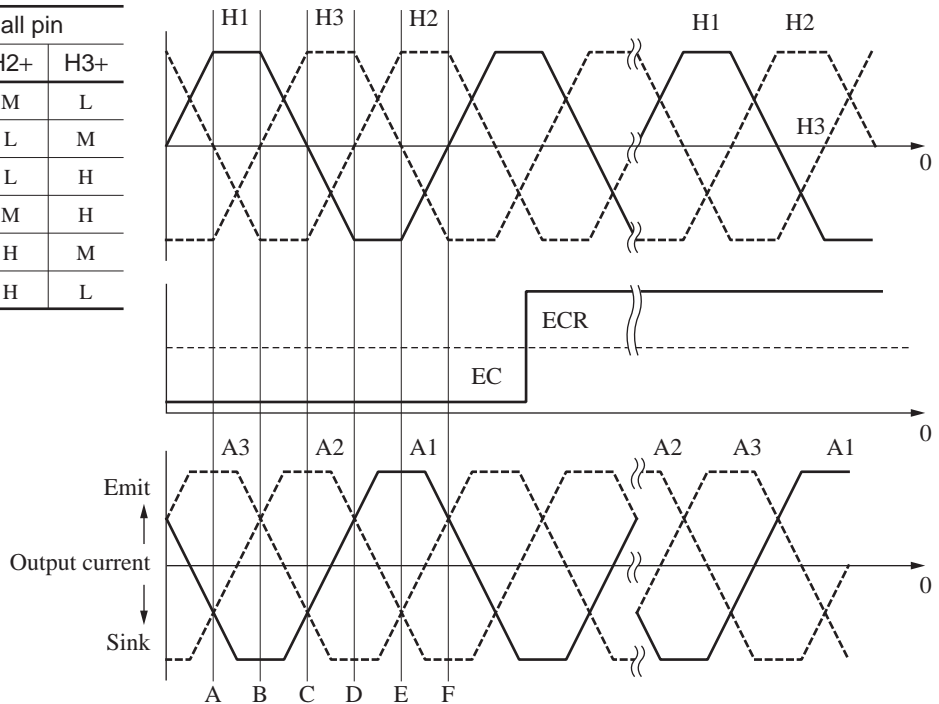

• Power consumption calculation method

You can find a rough value of electric power to be consumed in the IC in the following method and the use of EXCEL (computer soft ware) will enable you to put it on a graph.

Calculating formula:

1. Let an induced voltage generated in each phase as below:

(Reference to a motor center point)

$$E_{A1} = E_O \times \sin(X) \dots (1)$$

$$E_{A2} = E_O \times \sin(X+120) \dots (2)$$

$$E_{A3} = E_O \times \sin(X+240) \dots (3)$$

X: Phase angle

2. Let a current flowing in each phase as below:

$$I_{A1} = I_O \times \sin(X) \dots (4)$$

$$I_{A2} = I_O \times \sin(X+120) \dots (5)$$

$$I_{A3} = I_O \times \sin(X+240) \dots (6)$$

3. The voltages generated by a wire-wound resistance of a motor are:

$$V_{R1} = I_{A1} \times R \dots (7)$$

$$V_{R2} = I_{A2} \times R \dots (8)$$

$$V_{R3} = I_{A3} \times R \dots (9)$$

4. In each phase, add the voltage generated by an induced voltage and that by a wire-wound resistance.

$$V_{A1}' = (1) + (4)$$

$$V_{A2}' = (2) + (5)$$

$$V_{A3}' = (3) + (6)$$

5. As the lowest voltage in each phase angle must be 0 V, you can get the voltage to be generated in each phase by means of subtracting the lowest voltage from the voltage of the remaining two phases.

$$V_{A1} = V_{A1}' - \text{MIN}(V_{A1}', V_{A2}', V_{A3}') \dots (10)$$

$$V_{A2} = V_{A2}' - \text{MIN}(V_{A1}', V_{A2}', V_{A3}') \dots (11)$$

$$V_{A3} = V_{A3}' - \text{MIN}(V_{A1}', V_{A2}', V_{A3}') \dots (12)$$

6. Subtract the supply voltage from each phase's voltage found in item 5 and then multiply it by each phase's current, so that you can get the power consumption.

$$P = \sum_{n=1}^3 (12 - V_{An}) \times I_{An}$$

■ Application Notes (continued)

• Theory of thermal resistance

A chip temperature or the fin temperature can be understood in the same way as Ohm's Law.

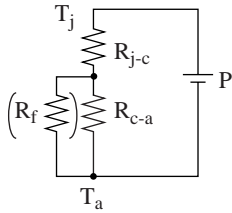

- T_j : Chip temperature
- T_a : Ambient temperature
- P : Electric power generated by IC
- R_{j-c} : Thermal resistance between a chip and a package
- R_{c-a} : Thermal resistance between a package and a surface of a heat sink or free air
- R_f : Thermal resistance between a package and surface of a heat sink

$$T_j = T_a + P \times (R_{j-c} + R_{c-a} // R_f)$$

Make sure that T_j does not exceed 150°C .

If it exceeds 150°C , you can suppress the rise of a chip temperature by adding a heat sink which is equivalent to R_f in the above figure.

$$T_j = T_a + P \times (R_{j-c} + R_{c-a} // R_f)$$

A package surface and the fin are available for a temperature measurement. But the fin part is recommendable for measurement because a package surface measurement does not always promise you a consistent measuring result.

■ Application Circuit Example

